

PS 5000, PS 6000

Operating and Diagnostic Terminal BT 6 Technical Information and Operation

Edition

101

PS 5000, PS 6000

Operating and Diagnostic Terminal BT 6 Technical Information and Operation

1070 080 078-101 (00.12) GB



E 2000

This manual is the exclusive property of Robert Bosch GmbH,
also in the case of Intellectual Property Right applications.
Without their consent it may not be reproduced or given to third parties.

Discretionary charge DM 10.-

Contents

		Page
1	Safety Instructions	1-1
1.1	Intended use	1-1
1.2	Qualified personnel	1-2
1.3	Safety markings possibly attached to the product	1-3
1.4	Safety instructions in this manual	1-4
1.5	Installation and assembly	1-5
1.6	Operation of the product	1-6
1.7	Retrofits and modifications by the user	1-7
1.8	Maintenance, repair	1-7
1.9	Working safely	1-9
2	Overview	2-1
3	Installation and Assembly	3-1
4	Electrical Connection	4-1
4.1	Power Supply (X1)	4-2
4.2	Communication (X2)	4-3
5	Operation	5-1
5.1	Control elements of BT 6 - Overview	5-1
5.2	Main menu items and their functionality - Overview	5-3
5.3	Selection of main menu items and navigation in sublevels	5-4
5.4	Quick mode	5-5
5.4.1	List of parameter numbers for quick mode	5-5
5.5	Special control functions	5-9
5.5.1	Display error messages	5-9
5.5.2	Select system language	5-9
5.5.3	Set LCD contrast	5-10
5.5.4	Inhibiting the Control Function (change code numbers)	5-10
5.5.5	Display electrode wear / Reset counter	5-12
5.5.6	Display data of the last weld	5-13
5.5.7	Display I/O signals	5-14
6	Maintenance	6-1
6.1	Battery	6-1
6.2	Fusing	6-2
6.3	BT 6 firmware version	6-3
6.3.1	Display firmware version	6-3
6.3.2	Load firmware version	6-3
A	Appendix	A-1
A.1	Abbreviations	A-1
A.2	Index	A-2

1 Safety Instructions

The product described here has been developed, manufactured, tested, and documented in compliance with the safety standards. This product normally poses no danger to persons or property if used in accordance with the handling stipulations and safety notes prescribed for their configuration, mounting, and proper operation.

Nevertheless, there is some residual risk!

Therefore, you should read this manual before installing, connecting or commissioning the product or programming the welding system using this terminal. Store this manual in a place to which all users have access at any time!

1.1 Intended use

The product described

- D serves in connection with a suitable weld timer (PS 5000, PS 6000) to
 - display and change parameters
 - display and reset faults
- D is suitable for operation in industrial environments (emission class A) in accordance with the following standards:
 - electromagnetic compatibility 89/336/EEC
 - EN 50082-2
 - EN 55011
 - EN 61000-4-2 to EN 61000-4-6

In residential environments, in trade and commerce as well as small enterprises class A equipment may only be used if it does not inadmissibly interfere with other equipment.

It is not intended for any other use!



DANGER!

The use for purposes other than the intended use may result in personal damage to the user or third persons or damage to the equipment, the workpiece to be welded or environmental hazards.

Therefore, our products should only be used for their intended purpose !

For operation in residential environments, in trade and commercial applications and small enterprises, an individual permit of the national authority or test institution is required; in Germany, please contact the Regulierungsbehörde für Telekommunikation und Post (RegTP) or its local branch offices.

The faultless, safe functioning of the product requires proper transport, storage, erection and installation as well as careful operation.

1.2 Qualified personnel

The requirements as to qualified personnel depend on the qualification profiles described by ZVEI (central association of the electrical industry) and VDMA (association of German machine and plant builders) in:

Weiterbildung in der Automatisierungstechnik

edited by: ZVEI and VDMA

Maschinenbau Verlag

Postfach 71 08 64

D-60498 Frankfurt.

This manual is designed for technicians and engineers with special training and specific knowledge of the welding technology. They require profound knowledge of the hardware components of the weld timer, the inverter unit, and the welding transformer.

Programming, start and operation as well as the modification of program parameters is reserved to properly trained personnel! This personnel must be able to judge potential hazards arising from programming, program changes and in general from the mechanical, electrical, or electronic equipment.

Interventions in the hardware and software of our products, unless described otherwise in this manual, are reserved to specialized Bosch personnel.

Tampering with the hardware or software, ignoring warning signs attached to the components, or non-compliance with the warning notes given in this manual can result in serious bodily injury or property damage.

Only electrotechnicians as recognized under IEV 826-09-01 (modified) who are familiar with the contents of this manual may install and service the products described.

Such personnel are

- D those who, being well trained and experienced in their field and familiar with the relevant standards, are able to analyze the work to be carried out and recognize any hazards.
- D those who have acquired the same amount of expert knowledge through years of experience that would normally be acquired through formal technical training.



DANGER!

An exception are persons with cardiac pacemakers!

Due to the strong magnetic fields arising from resistance welding, the function of cardiac pacemakers may be disturbed. This may cause the death or considerable health damages to persons with cardiac pacemakers!

Therefore, these persons should avoid the welding system.

We recommend posting a warning according to DIN 40023 at all entrances to factory halls containing resistance welding equipment.



No entry for persons with cardiac
pacemakers!
Danger!

Please note our comprehensive range of training courses. More information is available from our training center (Phone: +49 / 6062 / 78-258).

1.3 Safety markings possibly attached to the product



Warning of dangerous electrical voltage!



Warning of hazards associated with batteries!



Electrostatically sensitive components!



Disconnect mains plug before opening!



Lug for connecting PE conductor only!



Function ground, ground with low parasitic voltage



Connection of shield conductor only

1.4 Safety instructions in this manual



DANGEROUS ELECTRICAL VOLTAGE

This symbol is used to warn of a dangerous electrical voltage. The failure to observe the instructions in this manual in whole or in part may result in personal injuries.



DANGER

This symbol is used wherever insufficient or lacking compliance with instructions may result in personal injury.



CAUTION

This symbol is used wherever insufficient or lacking compliance with instructions may result in damage to equipment or data files.

- . This symbol is used to draw the user's attention to special circumstances.
- L This symbol is used if user activities are required.

Modifications in this manual as compared to a previous edition are marked by black vertical bars in the margin.

1.5 Installation and assembly



DANGEROUS ELECTRICAL VOLTAGE

Danger of life during installation work while systems are switched on!

Make sure that all plant sections undergoing operations during the installation are de-energized and sufficiently protected against accidental reclosing!



DANGER

The safety and accident prevention regulations as amended shall be observed!

Wear a protective helmet, safety shoes and gloves!



DANGER

Danger of injury and of damage to property through incorrect installation!

The units, and especially the operating elements, must be installed so as to be sufficiently protected against unintentional operation or contact.



CAUTION

Short-circuits!

When drilling or sawing out openings at and inside switch cabinets, metal burr may get inside modules that have already been installed. Similarly, water may leak and enter the modules when connecting cooling water lines.

Short-circuits and the destruction of the systems cannot be excluded.

Therefore, the modules should be well partitioned prior to any additional work! No liability is accepted in the event of non-compliance.



CAUTION

Capacitive or inductive interference!

Install connection and signal leads outside the switch cabinet so as to prevent equipment functions from being impaired.

1.6 Operation of the product

**DANGER**

In the environment of resistance welding systems, magnetic field strengths have to be expected which are above the limit values specified in VDE 0848 Part 4. Especially if manual guns are used, the limit values for extremities may be exceeded.

In cases of doubt, you should measure the field strength and take additional measures to ensure safety and health at work.

**DANGER**

Due to the strong magnetic fields arising from resistance welding, the function of cardiac pacemakers may be disturbed. This may cause the death or considerable health damages to persons with cardiac pacemakers!

Therefore, these persons should avoid the welding system.

We recommend posting a warning according to DIN 40023 at all entrances to factory halls containing resistance welding equipment.



No entry for persons with cardiac
pacemakers!
Danger!

**DANGER**

Danger of injury and of damage to property when operating the units outside a cabinet!

All units are designed to be installed in housings or cabinets and may only be operated in such housings or cabinets with the door closed!

**DANGER**

Danger of bruises through electrode movement!

All users, line designers, welding machine manufacturers and welding gun producers are obliged to connect output signals which initiate the electrode movement so that the applicable safety regulations are complied with.

For example, by means of "Two-handed start", fences, light barriers etc. the risk of bruises can be considerably reduced.

1.7 Retrofits and modifications by the user

**DANGER**

Modifications to the product may have negative effects on the safety of the unit!

The possible consequences include death, severe or light injury (personal injury), damage to property or environmental hazards.

Therefore, please contact us prior to making any modifications. This is the only way to determine whether changes can be made without any problems.

1.8 Maintenance, repair

**DANGEROUS ELECTRICAL VOLTAGE**

Prior to any maintenance work - unless described otherwise - the system must always be switched off!

In the event of necessary measurement or test procedures on the active system, these have to be performed by skilled electrical personnel.

**DANGER**

Danger of life through inappropriate EMERGENCY-STOP devices! EMERGENCY-STOP devices must be active and within reach in all system modes. Releasing the EMERGENCY-STOP device must by no means result in an uncontrolled restart of the system! First check the EMERGENCY-STOP circuit, then switch the unit on!

**DANGER**

If handled improperly, lithium batteries may cause cauterization or explode! Therefore:

Do not open forcefully, recharge, heat above 100 degrees Celsius or throw batteries into fire!

**CAUTION**

Only spare parts approved by Bosch may be used!

Only use original replacement batteries! Spent batteries or accumulators must be disposed of as hazardous waste!

**CAUTION**

Observe all precautions for ESD protection when handling modules and components! Avoid electrostatic discharge!

The following protective measures must be observed for modules and components sensitive to electrostatic discharge (ESD)!

- D Personnel responsible for storage, transport, and handling must have training in ESD protection.
- D ESD-sensitive components must be stored and transported in the prescribed protective packaging.
- D ESD-sensitive components may only be handled at special ESD-workplaces.
- D Personnel, working surfaces, as well as all equipment and tools which may come into contact with ESD-sensitive components must have the same potential (e.g. by grounding).
- D Wear an approved grounding bracelet. The grounding bracelet must be connected with the working surface through a cable with an integrated 1 M Ω resistor.
- D ESD-sensitive components may by no means come into contact with chargeable objects, including most plastic materials.

1.9 Working safely

**DANGER**

If the start signal is present on fault reset (Quit), the weld timer immediately starts the program sequence! Hazardous machine movements may be the result!

Therefore, before fault reset, you should make sure that there are no persons in the danger zone of the welding equipment!

**DANGER**

During operation of the welding equipment welding splashes are to be expected! The consequence may be injuries to the eyes or burns.

Therefore:

- wear protective goggles
 - wear protective gloves
 - wear flame-retardant clothes
-

**DANGER**

Danger of injury at sheet metal edges and danger of getting burnt at the parts to be welded!

Therefore: - wear protective gloves

**CAUTION**

The strong magnetic fields arising in connection with resistance welding may cause lasting damages to wrist watches, pocket watches, or cards with magnetic stripes (e.g. EC cards).

Therefore, you should not carry any such items on you when working in the direct vicinity of the welding equipment.

Notes:

2 Overview

This manual contains information on

- D the mechanics
- D the electrical connection and
- D the functions of the BT 6.



CAUTION

Danger of malfunctions and damage!

Wrong installation, faulty connection or improper operation can lead to unexpected or wrong unit reactions and hence to hazardous situations at the welding station.

So please respect the details in the present manual.

The BT 6 is a stationary or portable control and diagnostic terminal for your Bosch weld timer and can be used in connection with the PS 5000 and PS 6000 series of weld timers.

It is intended for

- D stationary (e.g. in the control panel of the welding station), or
- D mobile operation (e.g. in a portable housing).

The BT 6 supports the following functions:

- D Display and reset of all faults currently active in the timer
- D Display and change of important welding and process data.



BT 6 - built-in unit

The BT 6 has been designed for the display and parameter setting of production-specific data, because access to the complete range of timer functions is not necessary during normal operation. If you need to access all available programming and parameter input features of the weld timer, you should use a PC with the "BOS" welding software installed.

As a standard, the BT 6 is delivered for installation in a control cabinet, however, it is also available as a manual control terminal with a plastic housing and a magnet on the back side for quick storage.



BT 6 - manual control terminal

The operation of the BT 6 is described in section 5.

3 Installation and Assembly

Weight:	Built-in unit:	approx. 0.5 kg
	Manual programming terminal:	approx. 0.8 kg
Location:	desk or hinged frame, control cabinet, portable housings.	
	Sealed as per IP 65	
Orientation:	any orientation possible	
Degree of protection:	as per EN 60529.	
	Built-in unit:	
	BT 6 front face:	IP 65
	BT 6 back face:	IP 20
	Manual programming terminal:	IP 54
Operating temperature range:	0_C to +50_C	
Storage temperature range:	-20_C to +60_C	
Air humidity:	max. 75% on annual average, condensation is not permitted.	

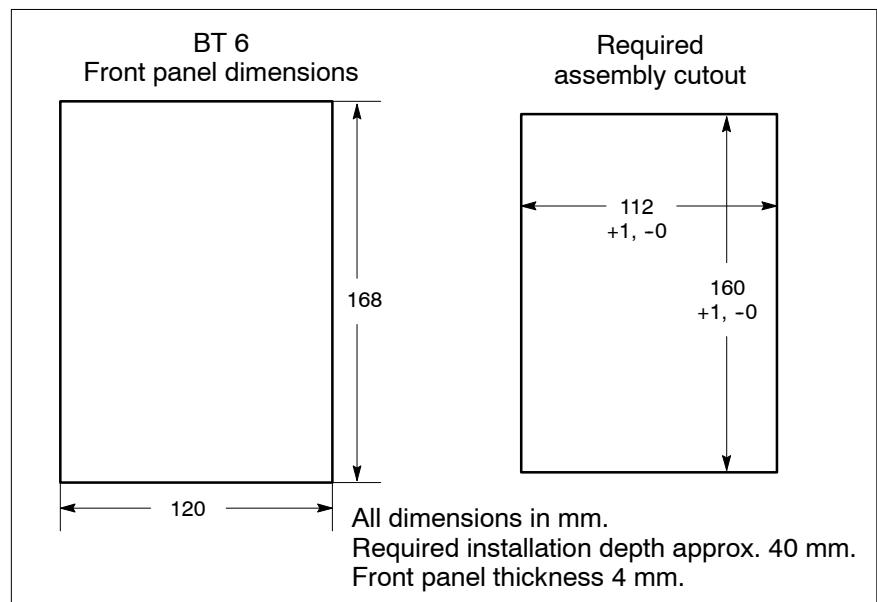

- L Please refer to the information in chapter "Safety Instructions" relative to installation and assembly.
- L Install the BT 6 so that ergonomic operation is guaranteed. The optimum reading angle of the LCD display is approx. 90°. When permanently installed, the operator must have an unobstructed view of all moving machine parts at all times! Remember how quickly the front panel can become dirty with a stationary inclined or horizontal installation.
- L Avoid installation places which are exposed to direct sunshine (reduction of display legibility; additional heat).
- L Provide a minimum upper and lower clearance of at least 30 mm for ventilation and cable routing.
- L For stationary installation: Keep as far as possible away from sources of interference, however at least 25cm. With strong magnetic fields we recommend the installation of partition plates.
- L Run all connection cables in loops, and use strain reliefs for all cables.

- L Fix the BT 6 with the 2 screw terminals supplied (maximum thickness of the mounting wall: 14 mm).
For this purpose, first insert the BT 6 into the assembly cutout and then engage the screw terminals in the lateral recesses of the BT 6 housing.
Then tighten the screw terminals.

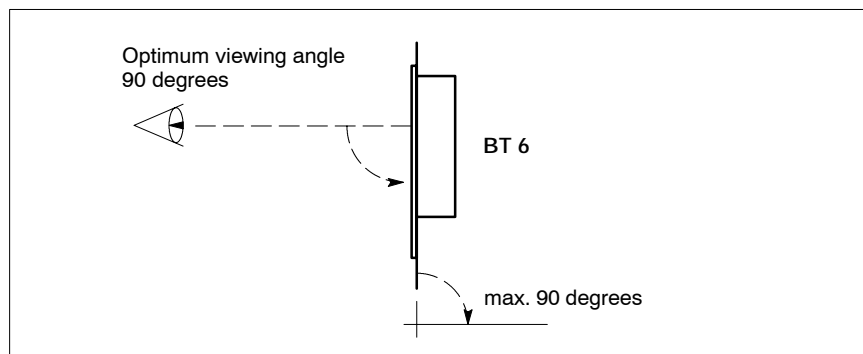

Recommended mounting orientations for stationary operation

4 Electrical Connection

For operation, the BT 6 needs the power supply to X1 as well as the communication port X2 (RS 232C, connected to X1 of the weld timer).

Location of the individual ports:

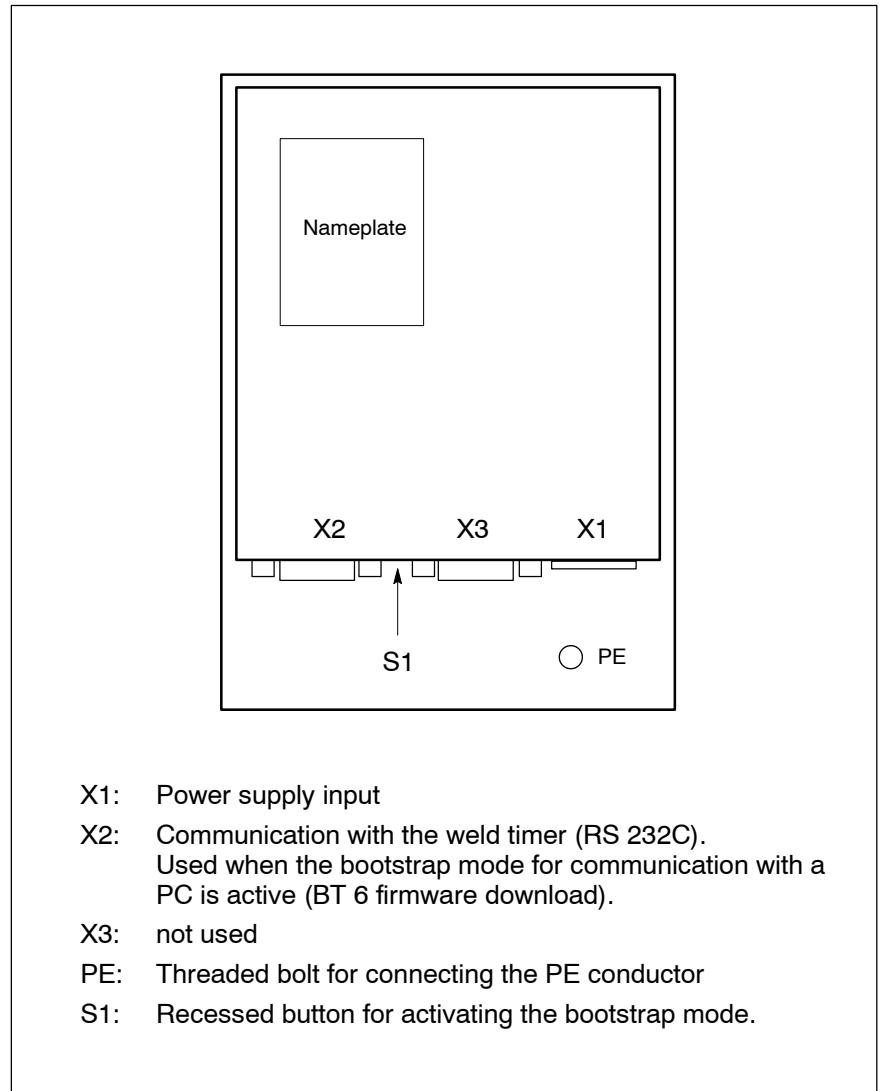

The control terminal may be connected and disconnected while the timer is running.

Communication with the timer is automatically established when X2 has been linked, if the BT 6 power supply (X1) had previously been interrupted. If the BT 6 power supply had not been previously interrupted, the BT 6 signals that communication with the weld timer is not possible.

In this case, simply press the  key on the BT 6 in order to establish communication.

4.1 Power Supply (X1)

Connection:	Screw-type terminal connector, Phoenix Combi-con, 3-pole, max. 2.5 ² , MSTBV 2.5 / 3 - GF. Mating connector (female) is comprised in the delivery.
Power supply :	Safety extra-low voltage (SELV) in accordance with DIN EN 61131. 19.2 ... 30.2 V _{DC} ; typ. 24 V _{DC} Residual ripple max. 10 %.
Power input :	< 0.3 A
Peak current:	0.5 A
Protection against polarity reversal:	Protective diode
Fusing	through semiconductor fuse, self-regenerating. For more information, refer to page 6-2.

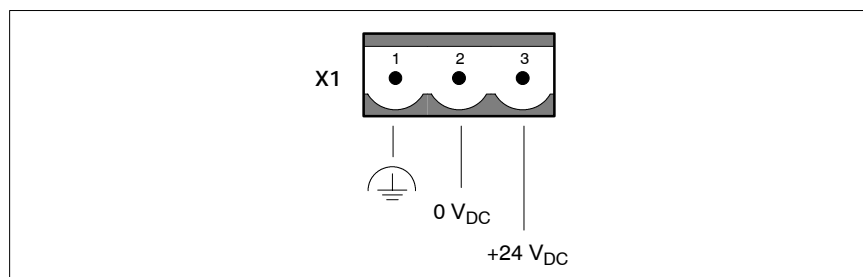

Terminal assignment on X1

- The BT 6 can be supplied from, e.g., the X5 power output of the weld timer.
- If shielded cables are used, connect the shield conductor to pin 1.
- The PE bolt is specifically provided for connecting the PE conductor. Operational safety is increased by using the PE connection. Use a separate conductor with a minimum area of 1.5 mm² for this connection.

4.2 Communication (X2)

Connection:	Subminiature D, female, 9-pin
Type:	RS 232C, electrically isolated
Cable length:	max. 15m
Cable type:	LiYCY; shielded, concentrically stranded; min. core area of 0.25 mm ²
Transmission rate:	19200 bit/s
Parameter:	8E1 (8 data bits, even parity, 1 stop bit)
Transmission:	PS5000 block protocol with CRC16

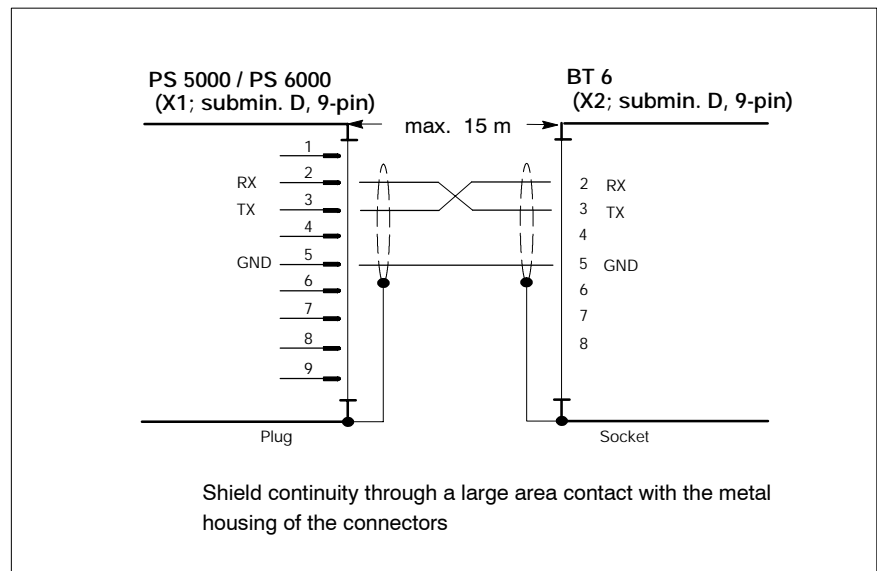

Connection of PS 5000 / PS 6000 to BT 6

Notes:

5 Operation

The BT 6 gives you access to important user- and control-specific data of the production process (e.g. display/modification of welding parameters, reset counters after electrode change, display of I/O signals present, etc.).





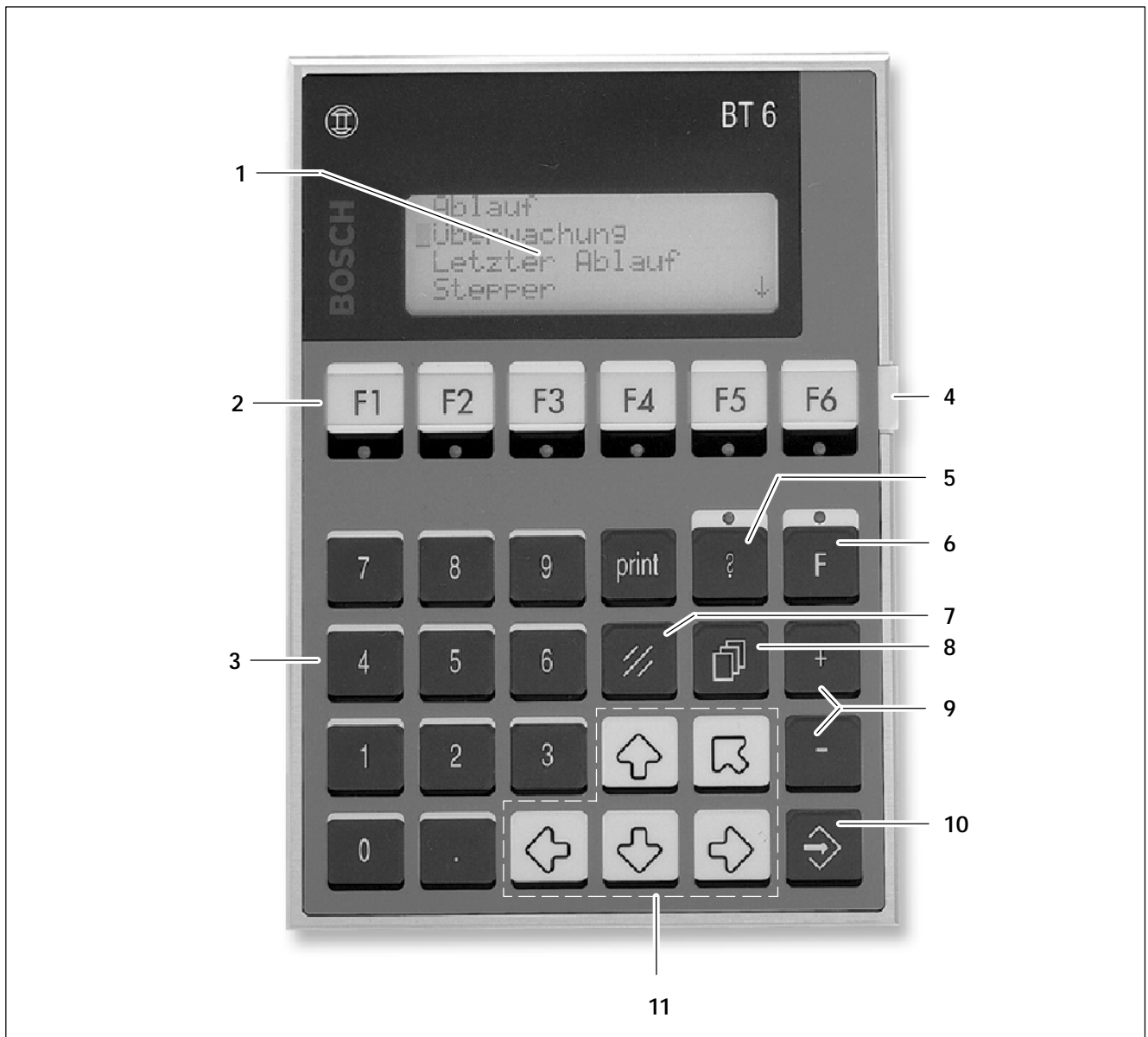

CAUTION

Possibility of damages to the system or the workpiece!
Do not change any data without reason. All data is transmitted online into the weld timer. Incorrect data settings may cause damages to the system or the workpiece!

5.1 Control elements of BT 6 - Overview



- 1 **Display.**
4 lines with 20 characters each can be displayed.
For contrast setting, refer to page 5-10.
- 2 **Function keys for direct selection of a main menu entry.**
An integrated LED indicates the main menu entry activated by a permanent light. Events assigned to such a sub-level are signaled by a flashing LED (e.g. "Stepper status" or "Maximum electrode life" in "STEPPER" sublevel).
The main menu options assigned to the individual function keys depend on your timer type.
- 3 **Numerical keys including decimal point for input of numerical values.**
In connection with the minus key (cf. 9), negative numerical values may be entered.
- 4 **Insertable stripes for labeling the function keys (cf. 2).**
The delivery contains a labeled ("F1" to "F6") and an unlabeled insertable stripe.
- 5 **Fault display key.**
When a fault is present, the integrated LED flashes. By pressing a key, you may branch to the fault display from any other display and back to your starting point. Within the fault display, the BT 6 shows all currently active faults automatically one by one. Refer to page 5-9.
To reset all active faults simultaneously: cf. item 7.
- 6 **Key for direct selection of parameters.**
The integrated LED is lit during parameter selection. By pressing the key again, you may jump directly to the selected parameter.
For more information on "Quick Mode", refer to page 5-5 ff.
- 7 **Delete/Quit button**
Deletes numerical values and resets active faults (timer is returned to "Ready" status).
- 8 **Return key.**
Return to the main menu.
- 9 **Plus and minus keys.**
Decrement or increment the value in the display field, or change over between options (e.g. ON / OFF, SINGLE / REPEAT / SEAM etc.).
- 10 **Accept data key.**
The value displayed is accepted. Control parameters are directly transmitted to the timer.
- 11 **Navigation keys.**
 -  or  selects an input field or a menu item.
 -  or  steps sequentially through all display screens available within a menu level.
 -  jumps back by one menu level (to the display screen active before the "F1" to "F6" or "F" keys were pressed).

5.2 Main menu items and their functionality - Overview

The scope of functions depends on the timer type connected! For example, the number and representation of parameters or menu items offered may be different, depending on the timer type used. For this reason, the functionality of menu items or parameters will not be dealt with in detail in the manual, which will rather be limited to the handling of the BT 6.

The following Overview shows the maximum scope of functions. It may be limited for your timer type:

D Sequence. Options:

- Display and change important parameters of the individual welding schedules (programs) (e.g. squeeze times, weld times including heat values of all 3 current blocks, cool times, impulses and upslope/down-slope times in the 2nd current block, hold time, off time, etc.)

D Monitoring. Options:

- Activate / deactivate current monitoring
- Display and change tolerance limits

D Last sequence. Options:

- Information which schedule (program) ran last in the timer
- For all programs: Display showing commanded/actual current and mean heat value during last sequence

D Stepper. Options:

- Display wear, remaining parts and current status of all electrodes (tip dress request, prewarning, end of stepper (electrode life))
- Acknowledge replacement of electrodes (reset counter)

D Correction in %. Options:

- Display and change the correction values for heat and pressure, for schedules and electrodes separately

D Pressure. Options:

- Display and change the basic pressure
- Activate/deactivate the pressure profile, display and change individual pressure profile values

D Diagnostics. Options:

- Status display of all I/O signals

D FPO (freely programmable output). Options:

- Activate / deactivate the output
- Display and change on/off times

D Sequence setup. Options:





- Display the timer type and firmware version
- Turn sequence inhibition on/off, globally for all schedules
- Turn "weld internal" on/off, globally for all schedules

D Setup BT. Options:

- Display the control terminal type and firmware version
- Set the LCD contrast
- Set the language
- Display and change code numbers

5.3 Selection of main menu items and navigation in sublevels



L Proceed as follows:

1. Press  key.
2. Move the cursor to the desired line with the keys  or .
3. Press  key.



The BT 6 changes to the selected sub-level.

The display structure may be different in the individual sublevels. As a rule, a sublevel may consist of one or several screens in which data can be displayed, selected and changed, if necessary.



D In order to get to the **next/previous** screen within a sublevel:

Use  or  key.

D In order to move the cursor **by lines** within a screen:

Use  or  key.

D To **change data**:

Set cursor to the line of the input field. Then use numerical keys, ,  or  keys.

D To **confirm data changes**:

Press  key.

D To **abort data changes**:

Press  key.

L You may press the  key at any time in order to go back from any screen to the **highest menu level**

- or -















press the  key in order to return to the **previous menu level**.

. In order to get to the individual screens of a sublevel without any de-tours, you may also use **Quick Mode**.

For more information on Quick Mode, refer to section 5.4.

5.4 Quick mode

You may use the Quick mode in order to call up a certain screen of any sub-level without any detours.

- L Proceed as follows:
 - . You may press
 - the  key at any time in order to go back to the highest menu level and then press
 - the  key in order to return to the previous menu level.
 - 1. Press  key.
 - The BT 6 changes to Quick mode. This condition is indicated by the lighted integrated key LED.
 - The screen for selecting a parameter number is displayed.
 - Line 1: QUICKMODE
 - Line 2: Schedule <#> or electrode <#>
 - Line 3: Parameter # <#>
 - Line 4: <Description of parameter in plain text>
 - 2. If it is necessary to select a certain welding schedule or a certain electrode, move the cursor with the  or  key to line 2 and set the desired number.
 - Use the number keys, the keys  or  for this purpose.
 - 3. If you have used the number keys for selection, press  in order to display the selected number.
 - 4. Move the cursor to line 3 with the  or  keys and enter the desired parameter number with the number keys, or keys  or . An overview of the parameter numbers available is given in the next table.
 - 5. If you have used the number keys for parameter selection, press  in order to display the selected parameter number.
 - . Line 4 shows the related parameter name in plain text. When selecting a parameter number that is not available or not defined, the BT 6 will display the text "undefined" in line 4.
 - 6. Press  key.
 - The BT 6 changes to the selected sub-level. The integrated key LED goes off.

5.4.1 List of parameter numbers for quick mode

- . The availability of individual parameter numbers depends on the timer type connected!

Active range	Description (alternative description)	Parameter number	
Weld program sequence	1.Squeeze time extended squeeze time	1	
	Squeeze time	2	
	1.Weld time Pre-heating weld time	3	
	1.Heat Basic heating current	4	
	1.Cool time	5	
	Upslope time Time of current rise	6	
	Upslope heat	7	
	2.Weld time Weld time	8	
	2.Heat Basic heating current	9	
	2.Cool time	10	
	Downslope time Current decrease time	11	
	Downslope heat	12	
	3.Weld time Post-heating weld time	13	
	3.Heat Post-heating current	14	
	3.Cool time	15	
	Hold time	16	
	Off time	17	
	Impulses 2.Weld time Impulses	18	
	Sequence mode Operating mode	19	
	Start inhibit (sequence)	20	
	Weld/no weld (sequence)	21	
	1.Halfwave a. Cool	22	
	Slope (on/off)	23	
	undefined	24	
	Current monitoring	Monitoring (global On/Off)	25
		Standard:	-
		Current Monitor. Std	26
Reference curr. Std		27	
Cond. Tol. Band Std		28	
Repeat factor Std		29	
Upper Tolerance Std		30	
Lower Tolerance Std		31	
Mix		-	
Current monit. 1.Wld		32	
Reference curr. 1.Wld		33	
Cond. Tol.Band 1.Wld		34	
Repeat factor 1.Wld		35	
Upper Tolerance 1.Wld		36	
Lower Tolerance 1.Wld		37	
Current monit. 2.Wld		38	
Reference curr. 2.Wld		39	
Cond. Tol.Band 2.Wld		40	
Repeat factor 2.Wld	41		





Active range	Description (alternative description)	Parameter number
	Upper Tolerance 2.Wld	42
	Lower Tolerance 2.Wld	43
	Current monit. 3.Wld	44
	Reference curr. 3.Wld	45
	Cond. Tol.Band 3.Wld	46
	Repeat factor 3.Wld	47
	Upper Tolerance 3.Wld	48
	Lower Tolerance 3.Wld	49
Pressure	Base-Pressure	50
	Pressure profile (On/Off)	51
	Only if pressure profile = ON:	-
	1.Pressure time	52
	1.Pressure value	53
	2.Pressure time	54
	2.Pressure value	55
	3.Pressure time	56
	3.Pressure value	57
	4.Pressure time	58
	4.Pressure value	59
	5.Pressure time	60
	5.Pressure value	61
	6.Pressure time	62
	6.Pressure value	63
	7.Pressure time	64
	7.Pressure value	65
	8.Pressure time	66
	8.Pressure value	67
	9.Pressure time	68
	9.Pressure value	69
	10.Pressure time	70
	10.Pressure value	71
Last sequence	Last weld	72
	Standard:	-
	Reference curr. Std	73
	Actual current Std	74
	Heat value Std.	75
	1.Weld time (pre-heating weld time):	-
	Reference curr. 1.Wld Commanded current 1.Wld	76
	Actual current 1.Wld	77
	%heat 1.Wld	78
	2.Weld time (weld current time):	-
	Reference curr. 2.Wld Commanded current 2.Wld	79
	Actual current 2.Wld	80
	%heat 2.Wld	81
	3.Weld time (post-heating weld time):	-
	Reference curr. 3.Wld Commanded current 3.Wld	82
	Actual current 3.Wld	83
	%heat 3.Wld	84

Active range	Description (alternative description)	Parameter number
Correction	Heat corr. schedule	85
	Pressure corr. sched	86
	Heat corr. electrode	87
	Pressure corr. elect	88
Sequence setup	Show type of timer	89
	Weld/no weld (timer)	90
	Start-Inhibit timer	91
Setup BT	Show type of BT6	92
	LCD - contrast	93
	Select language	94
	Not used	95 to 110
FPO (freely programmable output)	Free program. output (on/off)	111
	Only if FPO = On:	-
	1.Offtime	112
	1.Ontime	113
	2.Offtime	114
	2.Ontime	115
	3.Offtime	116
	3.Ontime	117

5.5 Special control functions









5.5.1 Display error messages

The BT 6 informs you through the flashing LED in key  that one or several errors have occurred.

- L Press the  key to display the active errors.
Line 1 of the display contains the number of currently active errors.
On display line 2 and thereafter, all errors are displayed one by one in plain text in intervals of approx. 1 second.
- D Press  to clear all active errors.
The timer will return to "Ready" status once the causes of the error have been eliminated.
- D Press  or  to exit the error display.
The system returns to the previous screen displayed.









5.5.2 Select system language

As a standard, the German and English languages have been integrated into BT 6.

- L Proceed as follows to set the language:
 1. Press  key.
 2. Move the cursor to the "SETUP BT" line with the keys  or .
 3. Press  key 3 times.
The cursor jumps to line "Select language".
 4. Select the desired language with key  or .
 - 0 = German; 1 = English.
 5. Press key  to confirm your selection
- or -
press key  in order to reset the input value to its default value.
 - L Press the  key in order to return to the highest menu level.
 - .
- In order to call up the language selection screen (steps 1 to 3), you may also use Quick Mode and parameter number 94.
For more information on Quick Mode, refer to page 5-5.

5.5.3 Set LCD contrast

The contrast of the display can be set as needed. In a well-lighted work environment you should increase the contrast, in a less bright environment you should reduce it. This will improve the readability of the display.

- L To set the contrast, proceed as follows:
 1. Press  key.
 2. Move the cursor to the "SETUP BT" line with the keys  or .
 3. Press  key 2 times.
The cursor is in line "LCD contrast".
 4. Then use numerical keys,  or  keys to set the desired contrast value.
 5. Press key , to set the contrast
-or-
press key  in order to reset the input value to its default value.
- L Press the  key in order to return to the highest menu level.
- . In order to call up the LCD contrast screen (steps 1 to 3), you may also use Quick Mode and parameter number 93.
For more information on Quick Mode, refer to page 5-5 ff.

5.5.4 Inhibiting the Control Function (change code numbers)

Parameter changes, or the display of data, can be inhibited with the help of code numbers (max. 4 digits).

Each existing main menu entry, and the "Change code number" function can thus be protected separately by a code number.

Without the input of the correct code number,

D access to the respective sublevel, or

D changing data in the sublevel is inhibited.

















CAUTION















Unauthorized alteration of or prying into key codes possible!

Always use a separate key code for protecting the "Change code number" function.

Only make this key code known to authorized people. People who know this key code can display all key codes stored and also change them!

- L Proceed as follows to set the key codes:
1. Press  key.
 2. Move the cursor to the "SETUP BT" line with the keys  or .
 3. Press  key 4 times.
The BT 6 expects input of a code number.
 4. Enter the code number required for changing code numbers (default setting ex factory and after replacement of firmware: 0). Numbers will not be displayed during input!
 5. Press  key.
When the correct key code has been entered, the system displays the first screen for defining code numbers:
Line 1: SETUP BT
Line 2: Change code number
Line 3: <free>
Line4: <Code number for changing code numbers>
 6. Enter the desired code number and press .
From that point onward, access to the "Change code number" mode is only granted if this code number is entered.
 7. Press  key.
The next code number screen will be displayed.
Line 1: Change code number
Line 2: <What is to be protected> (e.g. WELD SEQUENCE main menu entry)
Line 3: Read only .0
Line 4: Read/Write .0
If no code number is required, you have to enter the value "0".
D Code numbers in line "Read only":
Access to the submenu is protected by code number. Even when the correct code number has been entered, the data can only be displayed.
D Code numbers in line "Read/Write":
Data in the submenu can only be modified by entering the valid code number.
In order to enter code numbers at this point, proceed to 8. Otherwise, proceed to 10.
 8. Select the desired line with the  or  key (Read only, Read/Write) and enter the code number.
 9. Press key  to activate the code number displayed
-or-
press key  in order to reset the input value to its default value.
In order to enter more code numbers at this point, proceed to 8. Otherwise, proceed to 10.
 10. Press the  key in order to display the next screen for code number input.
In order to change code numbers, proceed to 8. Otherwise, proceed to 10.
- When all screens for code number input have been passed, the BT 6 will display the device type and data concerning the current firmware version by pressing the  key.
In this case, press the  key in order to return to the highest menu level.

5.5.5 Display electrode wear / Reset counter







- L Proceed as follows:
 1. Press  key.
 2. Move the cursor to the "STEPPER" line with the keys  or .
 3. Press  key.
The cursor is in line 2. The display shows the following data (one line per electrode):
 - Electrode number (counter no.)
 - Wear in %
 - the letters TD, PW, or ES, if applicable
(tip dress request, prewarning (stepper status), end of stepper (maximum electrode life))
 - Number of remaining parts
 4. Move the cursor up or down with the keys  or . If more than 3 electrodes (counters) are available, the  or  keys will trigger the display of more electrodes, if necessary.
If counters are to be reset after an electrode change, proceed to 6.
 5. Press the  key in order to leave the electrode display and return to the highest menu level.
 6. Move the cursor to the line containing the relevant electrode number (counter number) with the keys  or .
 7. Press the  key in order to select the electrode.
The text "replaced?" will be displayed.
 8. Replace electrode in question.
 9. Press the  key in order to reset the counter.
- L Press the  key in order to return to the highest menu level.
- . You may also use the function key assigned to this sublevel (normally F4) in order to call up the STEPPER screen (steps 1 to 3).
If the "Stepper status" or "Maximum electrode life" event occurs, the function key's integrated LED flashes.

5.5.6 Display data of the last weld

You may have the BT 6 show

- D the schedule that performed the last weld.
- D the commanded current, actual current and heat value most recently used by a certain schedule.

L Proceed as follows:





1. Press  key.
2. Move the cursor to the "LAST SEQUENCE" line with the keys  or .
3. Press  key.
The cursor is in line 1 (schedule).
Line 3 of the display contains the schedule that was last executed.
4. In order to display the data of the last weld of a certain schedule, enter the desired schedule number in line 1 and press key .
The BT 6 will open a screen which contains the commanded current, actual current and heat value of the last weld of this schedule.
If necessary, the sequence data can be called up individually for the 1st, 2nd and 3rd weld time by pressing the  key.
5. To display the data of other schedules:
Press the key until line 1 shows the text "Schedule". Proceed to 4.
In order to get back to the main menu: Press  key.

You may also use the function key assigned to this sublevel (normally F3) In order to call up the LAST SEQUENCE screen (steps 1 to 3).

5.5.7 Display I/O signals

All input and output signals of the timer can be visualized on the BT 6.

L Proceed as follows to display the signals:

1. Press  key.
2. Move the cursor to the "DIAGNOSTIC" line with the keys  or .
3. Press  key.

The BT 6 will open a screen in which a maximum of 8 signals can be displayed.

Line 1 specifies whether the signals displayed refer to inputs or outputs of the timer.

The following texts may be displayed in the beginning of line 2:

D "ser.":

the signals displayed are of the "serial" type (transmission via INTER-BUS). This signal type is additionally characterized by the "S" character in front of the 2-digit signal numbers (e.g. S00, S01, etc.).

D "ext.":

the signals displayed are of the "external" type (transmission via hardware I/O). This signal type is additionally characterized by an "E" (input) or an "A" (output) in front of the 2-digit signal numbers (e.g. E00, A00, etc.).

D "int.":

the signals displayed are of the "internal" type (signal is generated internally by the timer). This signal type is additionally characterized by the "I" character in front of the 2-digit signal numbers (e.g. I00).

The respective signal status (active / not active) is always signaled by the signal number and, separated by the character ":", by "0" (not active) or "1" (active).

4. To display additional maximally 8 signals, press . The BT 6 will open the next screen.

In order to return to the previous screen, press .

L In order to return to the main menu: Press  key.

6 Maintenance

6.1 Battery

A battery is integrated to back up the internal data.

Battery type: Lithium

Size: AA

Voltage: 3.6 V

When the remaining battery capacity becomes critical, the BT 6 generates the fault message "BT 6 battery low".

The LED in key  flashes (cf. page 5-9).

- L Include battery replacement in the regular maintenance schedule! Replacement: at least every 4 years.



CAUTION

Damages through improper handling of electronic components!
Therefore, batteries must be replaced by authorized technical personnel!



CAUTION

Loss of code numbers stored in BT 6!

If the BT 6 is not supplied with power at X1 for more than 1 minute because the battery is low or during battery change, all code numbers input may be deleted!

Therefore, check all your code numbers when you have replaced the battery!

Replacing the battery

1. Switch the unit off.
2. Remove all connection cables from the BT 6.
3. Make sure that the BT 6 cannot fall out of the assembly cutout and loosen the screw terminals on the sides of the BT 6 housing.
4. Take out the screw terminals and draw the unit out of the assembly cutout towards the front.
5. Lay the BT 6 front side facing down on a soft, even surface.
6. Loosen the housing screws (1) and the threaded bolts of the interfaces (2).

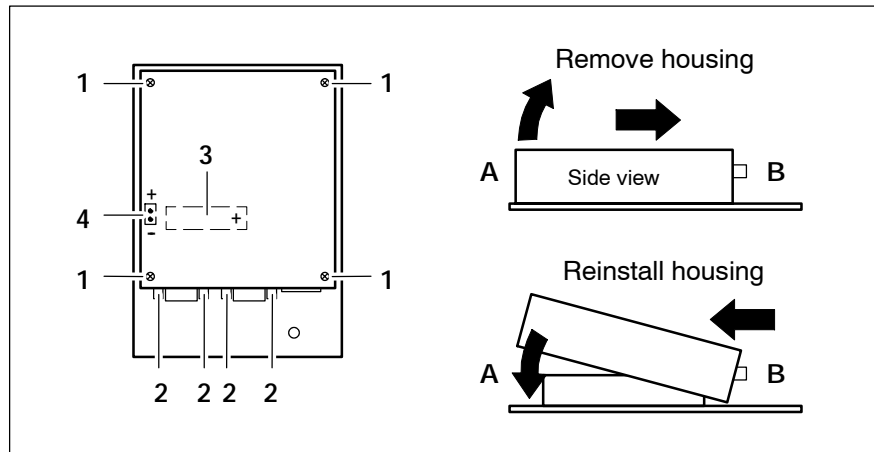

7. Carefully lift the housing on side A and then pull it off in the direction of the interfaces B. The battery (3) is located on the main board.
8. Remove the cable strap holding the battery.
9. Remove the battery connector (4) and take out the empty battery (for notes on battery, refer to section "Safety instructions", paragraph on "Maintenance/Repair").
10. Insert a new battery of the same type and secure the battery with a cable strap.
11. Ensure correct polarity and reinsert the battery connector (4) on the connector pole.
12. Put the housing carefully back on and screw the housing screws (1) and the threaded bolts of the interfaces (2) back in.
13. Reinstall the BT 6 and connect all cables properly again.
14. Turn the system back on and check whether your code numbers are still active in the BT 6.

6.2 Fusing

The BT 6 is equipped with a self-regenerating semiconductor fuse. Therefore, the fuse need not be replaced after a trip.

- L If the fuse was tripped, proceed as follows:
 1. Disconnect the unit from power (X1) for at least 20 seconds.
 2. Reapply the power.

Communication with the weld timer is automatically resumed.

6.3 BT 6 firmware version

The BT 6 has an integrated microprocessor with an operating program (firmware) that is stored in an 1 MByte flash memory.





Upon delivery, the most current firmware is installed on the BT 6. When the power supply is switched on, BT 6 will display the firmware version for approx. 2 seconds.

Normally, updates are not necessary.

6.3.1 Display firmware version

You may display the firmware version if the BT 6 is switched on and properly connected to the weld timer.

L Proceed as follows:

1. Press  key.
2. Move the cursor to the "SETUP BT" line with the keys  or .
3. Press  key.

Line 2: Type of BT 6 (e.g. "BT 6. 00")

Line 3: Firmware version (e.g. "1070 920852- 101")

Line 4: Firmware date (e.g. "26. 06. 2000")

L Press the  key in order to return to the highest menu level.

You may also use Quick Mode and parameter number 92 in order to call up the firmware version (steps 1 to 3).

For more information on Quick Mode, refer to page 5-5.

6.3.2 Load firmware version

In rare cases, it may be necessary to update the BT 6 firmware.

Firmware updates may only be carried out at the instruction of the Bosch service!

All code numbers (cf. page 5-10) will be reset to "0" by a firmware update.

For a firmware update, you need

- D access to the back of the housing of BT 6,
- D a pointed object for operating button S1 (for position, refer to page 4-1),
- D a PC with the "WinBlow" software installed,
- D a suitable connecting cable (BT 6 <-> PC; for wiring, refer to page 4-3) and
- D a data carrier (floppy disk, CD) with the corresponding firmware.

- L Proceed as follows:
1. Connect a V24 interface of your PC (COM1 or COM2) to X2 on the BT 6.
 2. Start the "WinBlow" software. Select the desired language and the V24 interface used.
 3. Insert the data carrier containing the firmware into your PC. Select the path and file name of the firmware. Firmware files have the filename extension ".hex".
 4. Click on "load firmware" command button.
You are prompted to set the bootstrap mode on the unit.
 5. Press the recessed key S1 on the back side of the BT 6.
Thus, the unit is switched from operating to bootstrap mode.
This condition is indicated by a recessed LED above key S1.
- . **If you want to exit the BT 6 bootstrap mode at this point, you have to interrupt the BT 6 power supply (pull out X1).
When the next step has been initiated, the BT 6 power supply must not be interrupted until the complete firmware has been loaded.**
6. Confirm at the PC that the BT 6 bootstrap mode has been activated. The firmware is now loaded into BT 6. A bar indicates the current status of the process.
 7. Wait until the PC signals the end of the transmission.
 8. Interrupt the BT 6 power supply for at least 5 seconds (remove X1). Then reinstall X1.
The BT 6 is booted with the new firmware.
 9. Connect the BT 6 to the weld timer.
Communication with the weld timer is automatically reestablished.
 10. Display the firmware version (cf. section 6.3.1, page 6-3).

A Appendix

A.1 Abbreviations

Abbreviation	Description
AC	Alternating Current
CT	Cool time
DC	Direct Current
DST	Down-slope time
ESD	electrostatic discharge Abbreviation of all references to electro- static discharge, e.g. ESD protection, ESD hazard
HLD	Hold time
IMP	Impulse
KSR	Constant current regulation
OFF	Off-time
PE	Protective Earth
PHA	Heat value
SQZ	Squeeze time
USR	Constant voltage regulation
UST	Up-slope time
WLD	Weld time
WT	Weld timer

A.2 Index

A

Air humidity, 3-1
Assembly, 1-5, 3-1
Assembly cutout, 3-1

C

Cable routing, 3-1
Code numbers, 5-10
Communication, 4-3
Connection, 4-1
Contrast , 5-10
Control elements, 5-1

D

Degree of protection, 3-1
Dimensions, 3-1

E

Electrode wear , 5-12
EMERGENCY-STOP devices, 1-7
Error messages, 5-9
ESD, A-1
 Electrostatic discharge, 1-8
 grounding, 1-8
 workplace, 1-8
ESD-sensitive components, 1-8

F

Firmware, 6-3
Firmware update, 6-3
Functionality , 5-3
Fusing, 4-2, 6-2

G

Grounding bracelet, 1-8

I

I/O signals, 5-14
Installation, 1-5, 3-1
Installation depth, 3-1
Intended use, 1-1
Interfaces, RS232, 4-3

L

Last weld, 5-13
Location, 3-1

M

Main menu items , 5-3
Maintenance, 1-7, 6-1
Minimum all-round clearance, 3-1
Modifications, 1-4
Modifications by the user, 1-7
Modules sensitive to electrostatic discharge. *See* ESD-sensitive components

N

Navigation, 5-4

O

Orientation, 3-1
Overview, 2-1

P

Parameter numbers for quick mode, 5-5
PE, A-1
Power input, 4-2
Power supply, 4-2

Q

Qualified personnel, 1-2
Quick mode, 5-5

R

Repair, 1-7
Replacing the battery, 6-1
Reset counter , 5-12
Retrofits, 1-7

S

Safety instructions, 1-4
Signals , 5-14
Spare parts, 1-7
System language, 5-9

T

Temperature ranges, 3-1
Test procedures, 1-7

V

Ventilation, 3-1

W

Weight, 3-1
Welding splashes, 1-9
Working safely, 1-9

X

X1, 4-2
X2, 4-3

