

*PSI 6000*

# **PSI 6000 Medium-Frequency Inverters**

with integrated control function

## **Technical Information**

Edition

# **101**

*PSI 6000*

# PSI 6000 Medium-Frequency Inverters

with integrated control function

## Technical Information

1070 080 059-101 (2001.04) GB



Reg. no. 16149-03

E 2000, 2001

This manual is the exclusive property of ROBERT BOSCH GMBH,  
also in the case of Intellectual Property Right applications.  
Without their consent it may not be reproduced or given to third parties.

Discretionary charge DM 10.-



# Contents

	Page
<b>1</b>	<b>Safety instructions . . . . . 1-1</b>
1.1	Safety instructions and symbols attached to the product . . . . . 1-1
1.2	Safety instructions and symbols used in this manual . . . . . 1-2
1.3	Intended use . . . . . 1-3
1.4	No admittance for persons fitted with cardiac pacemakers . . . . . 1-4
1.5	Qualified personnel . . . . . 1-5
1.6	Installation and assembly . . . . . 1-6
1.7	Electrical connection . . . . . 1-9
1.8	System perturbation . . . . . 1-12
1.9	Ensuring EMC of the completely assembled system . . . . . 1-13
1.10	Operation of the medium-frequency inverters . . . . . 1-14
1.11	Retrofits and modifications by the user . . . . . 1-15
1.12	Maintenance, repair . . . . . 1-16
1.13	Working safely . . . . . 1-17
1.14	CE conformity . . . . . 1-18
<b>2</b>	<b>Setup . . . . . 2-1</b>
2.1	Features . . . . . 2-1
2.2	Modules and components . . . . . 2-2
2.3	Function . . . . . 2-4
2.4	Monitoring . . . . . 2-5
2.5	Advantages and benefits of medium-frequency welding . . . . . 2-6
<b>3</b>	<b>Notes on Rating . . . . . 3-1</b>
3.1	Load diagrams . . . . . 3-2
<b>4</b>	<b>Commissioning . . . . . 4-1</b>
<b>5</b>	<b>Maintenance . . . . . 5-1</b>
<b>6</b>	<b>Malfunction . . . . . 6-1</b>
<b>7</b>	<b>Type overview . . . . . 7-1</b>
7.1	Features . . . . . 7-1

		Page
<b>8</b>	<b>PSI 6025.XXX L1</b> .....	<b>8-1</b>
8.1	Explanation of drawings .....	8-1
8.2	PSI 6025.XXX L1 front panel .....	8-2
8.3	Technical data, PSI 6025.XXX L1 .....	8-4
8.4	Dimensioned drawing, PSI 6025.XXX L1 .....	8-5
8.5	Electrical connection, PSI 6025.XXX L1 .....	8-6
8.6	Load diagram, PSI 6025.XXX L1 .....	8-7
8.7	Accessories, PSI 6025.XXX L1 .....	8-8
8.7.1	Dimensioned drawing, accessories kit .....	8-8
8.8	Ordering, PSI 6025.XXX L1 .....	8-10
<b>9</b>	<b>PSI 6100.XXX L1/L2/W1/W2</b> .....	<b>9-1</b>
9.1	PSI 6100.XXX L1/L2/W1/W2 overview .....	9-1
9.2	Explanation of drawings .....	9-1
9.3	PSI 6100.XXX L1/L2/W1/W2 front panel .....	9-2
9.4	Technical data, PSI 6100.XXX L1/L2/W1/W2 .....	9-4
9.5	Dimensioned drawing, PSI 6100.XXX L1/L2 .....	9-6
9.6	Dimensioned drawing, PSI 6100.XXX W1/W2 .....	9-7
9.7	Electrical connection, PSI 6100.XXX L1/L2/W1/W2 .....	9-8
9.8	Cooling water connection, PSI 6100.XXX W1/W2 .....	9-9
9.9	Load diagram, PSI 6100.XXX L1/W1 .....	9-11
9.10	Load diagram, PSI 6100.XXX L2/W2 .....	9-12
9.11	Accessories, PSI 6100.XXX L1/L2/W1/W2 .....	9-13
9.11.1	Dimensioned drawing, accessories kit .....	9-13
9.12	Ordering, PSI 6100.XXX L1/L2/W1/W2 .....	9-15
<b>10</b>	<b>PSI 6200.XXX W1/W2</b> .....	<b>10-1</b>
10.1	PSI 6200.XXX W1/W2 overview .....	10-1
10.2	Explanation of drawings .....	10-1
10.3	PSI 6200.XXX W1/W2 front panel .....	10-2
10.4	Technical data, PSI 6200.XXX W1/W2 .....	10-4
10.5	Dimensioned drawing, PSI 6200.XXX W1/W2 .....	10-5
10.6	Electrical connection, PSI 6200.XXX W1/W2 .....	10-6
10.7	Cooling water connection, PSI 6200.XXX W1/W2 .....	10-7
10.8	Load diagram, PSI 6200.XXX W1 .....	10-9
10.9	Load diagram, PSI 6200.XXX W2 .....	10-10
10.10	Accessories, PSI 6200.XXX W1/W2 .....	10-11
10.11	Ordering, PSI 6200.XXX W1/W2 .....	10-12
<b>11</b>	<b>PSI 6300.XXX L1/L2/W1/W2</b> .....	<b>11-1</b>
11.1	PSI 6300.XXX L1/L2/W1/W2 overview .....	11-1
11.2	Explanation of drawings .....	11-1
11.3	PSI 6300.XXX L1/L2/W1/W2 front panel .....	11-2
11.4	Technical data, PSI 6300.XXX L1/L2/W1/W2 .....	11-4
11.5	Dimensioned drawing, PSI 6300.XXX L1/L2 .....	11-6
11.6	Dimensioned drawing, PSI 6300.XXX W1/W2 .....	11-7
11.7	Electrical connection, PSI 6300.XXX L1/L2/W1/W2 .....	11-8
11.8	Cooling water connection, PSI 6300.XXX W1/W2 .....	11-9
11.9	Load diagram, PSI 6300.XXX L1/W1 .....	11-11
11.10	Load diagram, PSI 6300.XXX L2/W2 .....	11-12
11.11	Accessories, PSI 6300.XXX L1/L2/W1/W2 .....	11-13
11.11.1	Dimensioned drawing, accessories kit .....	11-13
11.12	Ordering, PSI 6300.XXX L1/L2/W1/W2 .....	11-15

		Page
<b>12</b>	<b>PSI 6500.XXX W1</b> .....	<b>12-1</b>
12.1	Explanation of drawings .....	12-1
12.2	PSI 6500.XXX W1 front panel .....	12-2
12.3	Technical data, PSI 6500.XXX W1 .....	12-4
12.4	Dimensioned drawing, PSI 6500.XXX W1 .....	12-5
12.5	Electrical connection, PSI 6500.XXX W1 .....	12-6
12.6	Cooling water connection, PSI 6500.XXX W1 .....	12-7
12.7	Load diagram, PSI 6500.XXX W1 .....	12-9
12.8	Accessories, PSI 6500.XXX W1 .....	12-10
12.9	Ordering, PSI 6500.XXX W1 .....	12-11
<b>13</b>	<b>CE declaration of conformity</b> .....	<b>13-1</b>
<b>A</b>	<b>Annex</b> .....	<b>A-1</b>
A.1	Index .....	A-1

Notes:

# 1 Safety instructions

The products described were developed, manufactured and tested in compliance with the fundamental safety requirements of the EU machine directive. These products normally poses no danger to persons or property if used in accordance with the handling stipulations and safety notes prescribed for their configuration, mounting, and proper operation.

**Nevertheless, there is some residual risk!**

Therefore, you should read this manual before installing, connecting or commissioning the products. Store this manual in a place to which all users have access at any time!

This manual describes the:

D PSI 6000 medium-frequency inverters

The functions of the integrated weld timer are described in a separate manual.

## 1.1 Safety instructions and symbols attached to the product



Warning of dangerous electrical voltage!



Lug for connecting PE conductor only!

## 1.2 Safety instructions and symbols used in this manual

---



### DANGEROUS ELECTRICAL VOLTAGE

This symbol is used to warn of dangerous electrical voltage. Failure to observe the instructions in this manual in whole or in part may result in personal injury.

---



### DANGER

This symbol is used wherever insufficient or lacking compliance with instructions may result in personal injury.

---



### CAUTION

This symbol is used wherever insufficient or lacking compliance with instructions may result in damage to equipment or data files.

---

- . Note: This symbol is used to draw the user's attention to special circumstances.
- L This symbol is used if user activities are required.

Modifications in this manual as compared to a previous edition are marked by black vertical bars in the margin.

### 1.3 Intended use

PSI 6000 MF inverters are designed for connection of PSG 3000 welding transformers.

These MF inverters are designed for use in

D resistance welding of metals and

D are suitable for operation in industrial environments as per DIN EN 50082-2 and 50081-2 on electromagnetic compatibility (EMC).

They are not intended for any other use!



#### **DANGER**

Any use other than for the purpose indicated may result in personal injury of the user or third parties or in damage to equipment, the workpiece to be welded, or environmental damage.

Therefore, our products must never be used for any other than their respective intended purpose!

---

**Note:** For operation in residential environments, in trade and commercial applications and small enterprises, an individual permit of the national authority or test institution is required; in Germany, please contact the Regulierungsbehörde für Telekommunikation und Post (RegTP) or its local branch offices.

The faultless, safe functioning of the product requires proper transport, storage, erection and installation as well as careful operation.

## 1.4 No admittance for persons fitted with cardiac pacemakers



### DANGER

**WARNING** for persons fitted with cardiac pacemakers!

To protect persons fitted with cardiac pacemakers, no-entry signs should be posted because pacemaker malfunction (missed pulses, total failure), pacemaker program interference or even program destruction is to be expected!!!

Note: We recommend that warning signs like the one shown below are posted at every entrance to manufacturing shops housing resistance-welding equipment:

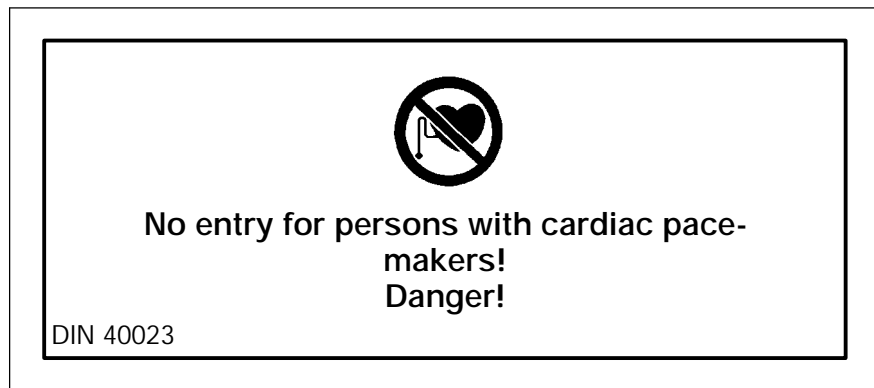

## 1.5 Qualified personnel

The requirements as to qualified personnel are based on the requirements profiles as defined by the ZVEI (Zentralverband Elektrotechnik und Elektronikindustrie – German Electrical and Electronic Manufacturers' Association) and the VDMA (Verband deutscher Maschinen- und Anlagenbau – German Engineering Federation) in:

**Weiterbildung in der Automatisierungstechnik**  
edited by: ZVEI and VDMA  
Maschinenbau Verlag  
Postfach 71 08 64  
D-60498 Frankfurt.

This manual is designed for technicians and engineers with special welding training and skills. They must have a sound knowledge of the hardware components of the weld control system, the PSI 6000 medium-frequency inverters and the welding transformers.

Interventions in the hardware and software of our products, unless described otherwise in this manual, are reserved to specialized Bosch personnel.

Tampering with the hardware or software, ignoring warning signs attached to the components, or non-compliance with the warning notes given in this manual can result in serious bodily injury or property damage.

Only skilled persons as defined in IEV 826-09-01 who are familiar with the contents of this manual may install and service the products described.

Such personnel are

- D those who, being well trained and experienced in their field and familiar with the relevant standards, are able to analyze the work to be carried out and recognize any hazards.
- D those who have acquired the same amount of expert knowledge through years of experience that would normally be acquired through formal technical training.



### **DANGER!**

**An exception are persons with cardiac pacemakers!**

The strong magnetic fields occurring in resistance welding may affect the proper functioning of pacemakers. This may be fatal or cause serious personal injury!

Therefore, persons with pacemakers must stay clear of resistance welding systems.

We recommend that warning signs as per DIN 40023 are posted at every entrance to manufacturing shops housing resistance-welding equipment.

---

Please note our comprehensive range of training courses. More information is available from our training center (Phone: +49 / 6062 / 78-258).

## 1.6 Installation and assembly

---

**DANGER**

Non-workmanlike installation or mounting may lead to personal injury or damage to property.

Therefore, it is essential that you take the technical data (environmental conditions) into account for installation or mounting.

Installation or mounting must be carried out by skilled personnel only.

---

**DANGER**

Insufficient degree of protection may be life-threatening or cause damage to property!

The degree of protection of MF inverters is IP 20. They must be installed in switchgear cubicles providing a degree of protection of no less than IP 54.

---

**DANGER**

Danger of injury and of damage to property through incorrect installation!

Devices and, in particular, operating means, must be installed so as to be properly safeguarded against unintentional operation or contact.

---

**DANGER**

Risk of injury from sharp-edged sheet metal!  
Wear protective gloves!

---

**DANGER**

Danger of personal injury and damage to property through inadequate fastening!

The place for installing the welding inverters, and their method of fastening, must be suitable for their weight!

Injuries and bruises may be caused by lifting weights which are too heavy or by sharp metal edges!

Due to the heavy weight of individual modules several persons are required for installation and assembly.

Wear safety shoes and safety gloves!

---

**DANGEROUS ELECTRICAL VOLTAGE**

Before the modules are installed, the respective mounting station must be safely isolated from supply and properly safeguarded to prevent unintentional or unauthorized reclosing.

---

**CAUTION****Short circuits!**

When cut-outs are drilled or sawed in switchgear cubicles, metal burr may get into modules already installed there. Or, when cooling water lines are connected, water may leak into the modules installed. The possibility of short circuits occurring in the process or even the destruction of the devices cannot be entirely ruled out.

Therefore, guard any existing modules well before you install a new module! Any and all warranty excluded in case of non-compliance.

---

**CAUTION****Heat accumulation!**

MF inverters must be mounted with a minimum clearance of 100 mm on top and at the bottom. Without this minimum clearance, heat may accumulate and cause inverter failure.

---

**CAUTION**

In the case of air-cooled MF inverters, the temperature inside the housing must stay within the specified range. MF inverters must always be operated under forced-air cooling conditions. Convection cooling will not be sufficient!

---

**CAUTION**

Leaks in the cooling water circuit may cause consequential damage! Cooling water leaks may damage adjacent components. Therefore, when mounting water-cooled modules, always ensure that other devices in the switchgear cabinet are well protected against leaking cooling water.

---

**CAUTION**

Damage to property through inappropriate or insufficient cooling of the medium-frequency inverters!

Water-cooled medium-frequency inverters may only be operated when the cooling water circuit is active! Condensation on water-carrying components must be prevented.

Damage to property through insufficient water quality in the cooling water circuit!

Deposits in the cooling system may reduce the water flow, thus impairing the performance of the cooling system with time.

Therefore, you should ensure that your cooling water has the following properties:

- D pH value : 7 to 8.5
- D Degree of hardness  $D_{\max}$  : 10 German degrees  
(1 German degree = 1.25 British degrees = 1.05 US degrees = 1.8 French degrees)
- D Chlorides : max. 20 mg/l
- D Nitrates : max. 10 mg/l
- D Sulfates : max. 100 mg/l
- D Insoluble substances : max. 250 mg/l

Tap water usually meets these requirements. However, an algicide should be added.

- 
- L Make sure that all contact surfaces are bright, i.e. free of paint, plastic coating or dirt/oxidation.
  - L Mount the device in a vertical position.

## 1.7 Electrical connection

---



### DANGEROUS ELECTRICAL VOLTAGE

The mains voltage is associated with many dangers!

Possible consequences of improper handling include death or most severe injuries (personal injuries) and damage to property. For this reason, the electrical connection must always be made by an electrical expert in compliance with the valid safety regulations, the mains voltage and the maximum current consumption of the individual units of the equipment.

The mains voltage must match the nominal voltage given on the nameplate of the product!

The equipment must be appropriately fused on the supply side!

Prior to connecting an MF inverter, the following must be strictly observed:

- D Power OFF.
  - D Provide a safeguard to prevent unintentional reclosing.
  - D Verify that the system is safely isolated from supply and de-energized.
  - D Connect to earth and short circuit.
  - D Cover up or safeguard all live parts.
- 



### DANGEROUS ELECTRICAL VOLTAGE

Handling live parts at mains voltage may result in death, severe bodily injury or considerable damage to property unless appropriate precautions are taken.

For this reason, the electrical connection must always be made by an electrical expert in compliance with the valid safety regulations, the mains voltage and the maximum current consumption of the individual units of the equipment.

Incorrect mains voltage may render the system dangerous or cause electrical component failure!

Therefore, please ensure the following:

- D The mains voltage must match the nominal voltage given on the nameplate of the product!
  - D Mains voltage fluctuation or variation from the nominal voltage must be within the specified tolerance range (see Technical Data).
  - D The equipment must be appropriately fused on the mains side!
  - D Before carrying out any work on the mains system or welding system connections it must be ensured that the MF inverter has been safely isolated from the supply for at least 5 minutes (capacitor discharge time).
  - D Proper and well insulated tools must be used for handling electric connections!
-

**DANGEROUS ELECTRICAL VOLTAGE**

Danger of life through insufficient protective conductor system! The medium-frequency inverters must be connected to the protective earthing (PE) circuit of the system. Please ensure that the cross-sectional area of cables used for protective conductor wiring is sufficiently large. The electrical continuity of the protective earthing circuit must be verified in accordance with EN 60204 Part 1.

**DANGEROUS ELECTRICAL VOLTAGE**

Any residual current devices used on the mains side of the MF inverters to protect persons getting into direct or indirect contact must be of type B. As per IEC 60 755, these devices must also be capable of safely detecting possible residual currents of 1 kHz frequency.

**DANGEROUS ELECTRICAL VOLTAGE**

MF inverters may be operated in earth neutral systems only.

Protective grounding is the only protective measure permitted as per prEN 50 178 (DIN VDE 0160)!

Operation in systems with ordinary residual-current circuit-breakers is not permitted because of the risk that residual currents may flow from the intermediate circuit to earth and back into the system without tripping the RCCB.

In the case of operation with an isolating transformer, single-sided grounding of the intermediate circuit is not permitted.

**DANGEROUS ELECTRICAL VOLTAGE**

Operation in unbalanced networks (only one network phase grounded) is not permitted.

Note: It is recommended that the whole welding system be operated within a separate welding power network.

The MF inverters are approved for operation in grounded systems (TT or TN systems). For operation in non-grounded systems (e.g., IT systems), an isolation transformer with its center point of earth potential in secondary circuit must be used.

**CAUTION**

Connecting lines and signal lines must be laid so as to avoid negative effects on the function of the units through capacitive or inductive interference!

Interference is frequently coupled and de-coupled in long cables. Therefore, medium-frequency inverter cables and control cables must be routed separately. The influence of interfering cables on cables susceptible to interference can be minimized by keeping the following distances:

- D > 100 mm if cables are run in parallel for < 10 m,
- D > 250 mm if cables are run in parallel for > 10 m.

MF inverters should be mounted close to the welding systems so as to avoid cable lengths of more than 25 m.

---

**CAUTION**

Connection cables may come off and apply dangerous voltage to system components!

It is crucial that cables are properly fixed.

---

- L **PE connection** : Connect to a central earth point. Make sure that cable cross-sectional areas are sufficiently large!
- L All conductor cross-sections must be large enough for for the loads to be connected.
- L **U1 connection** : Connect to L1 system phase.
- L **V1 connection** : Connect to L2 system phase.
- L **W1 connection** : Connect to L3 system phase.
- L **U2 and V2 welding transformer outputs** : Connect to PSG 3000 (U, V) welding transformer.

## 1.8 System perturbation

When operating a medium-frequency inverter a harmonic load must be accounted for in the mains system. This load is caused by the "B6" rectifier circuit with a smoothing capacitor.

The following figure shows the typical curve of the mains voltage (top) and the related mains current (bottom) in one phase during the welding process:

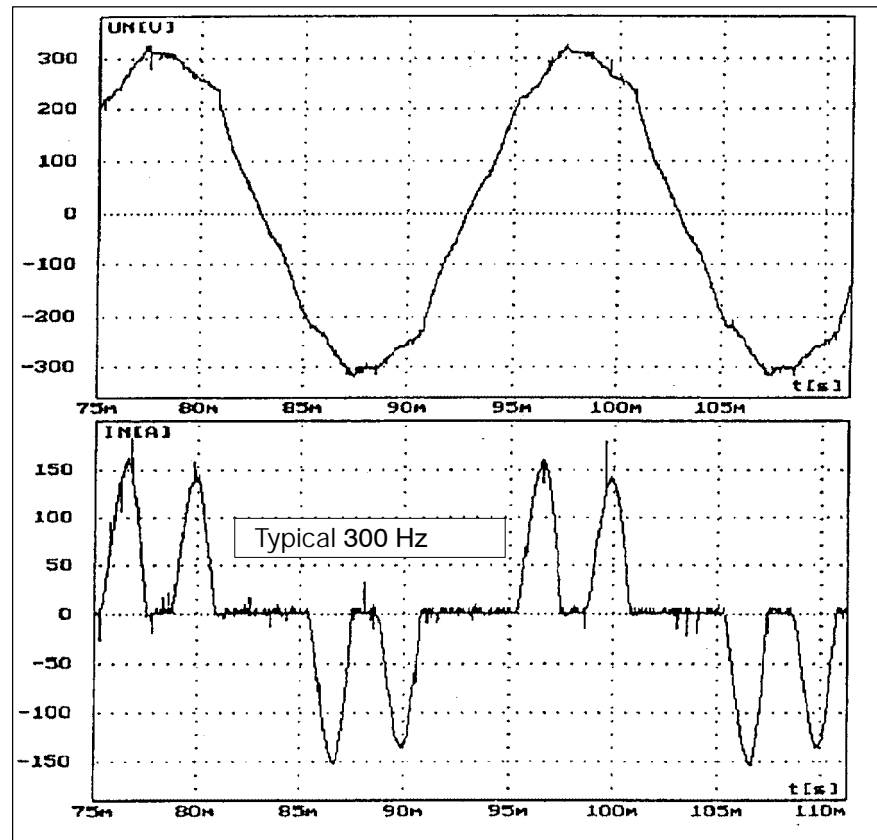

The 5th, 7th, 11th, 13th, 15th, and 17th harmonic wave are the characteristic harmonics of the mains current curve.

The harmonic component depends on the welding power.

Note: The harmonic content may be considerably reduced, e.g., by using smoothing reactors with 4% short-circuit voltage.

## 1.9 Ensuring EMC of the completely assembled system

Note: The completely assembled system with the welding transformer complies with prEN 50240, the EMC product standard for resistance welding systems, and EN 55011 (October 1997), EMC product family standard class A, group 2, rated current > 100 A.

- D Only for industrial applications.
- D Safe clearance from residential areas  $\geq 30$  m.
- D Safe clearance to communication systems (wireless, telephone)  $\geq 10$  m.
- D Cable length of mains feeder  $\geq 10$  m.
- D Interference suppression measures: When switchgear cabinet doors are open, operation of radio devices or cell phones is permitted only beyond a safe clearance of  $\geq 2$  m.
- D The assessment and certificate of conformity of a competent authority concerning compliance with the fundamental EMC protection is available.

If these components are integrated into a portable welding box system (SCHWEISSKOFFER), the CE marking is affixed to the portable welding box pursuant to EMC Directive 89/336/EEC. No further EMC testing of the portable welding box is required.

## 1.10 Operation of the medium-frequency inverters



### DANGER

Danger of personal injury and damage to property if devices are operated before they have been properly installed!

The devices are designed to be installed in housings or switchgear cabinets and must not be operated unless properly installed and switchgear cabinet doors are closed!



### DANGER

Danger of personal injury and damage to property through missing or false interpretation of fault messages!

Therefore, closing of the temperature contact (thermostatic switch, break contact) must inhibit the connected timer!

As regards fault analysis, see also the section on "Malfunction".



### DANGER

Danger of bruises through electrode movement!

All users, line designers, welding machine manufacturers and welding gun producers are obliged to connect the output signal of the Bosch weld timer which initiates the electrode movement so that the applicable safety regulations are complied with.

The risk of bruises can be considerably reduced by means of, e.g., two-handed start, guard rails, light barriers etc.



### CAUTION

Damage to property through insufficient cooling of the modules!

Ensure that the modules are properly cooled during operation. Condensation on water-carrying components must be prevented. In the case of air-cooled MF inverters, the temperature inside the mounting station must remain in the specified range. In the case of water-cooled MF inverters, the maximum permitted cooling-water temperature must not be exceeded.



### CAUTION

Damage to property through excessive welding current!

The maximum welding current depends on the thyristor unit of the medium-frequency inverter and the welding transformer in use. It must not be exceeded.

Therefore, the user must check the load in each case. See also the section on "Load diagrams".

Any and all warranty excluded in case of non-compliance.

## 1.11 Retrofits and modifications by the user

---

**DANGER**

Retrofits or modifications may have negative effects on the safety of the unit!

Product modification may cause death, severe or light personal injury, damage to property or environmental damage.

Therefore, please contact us prior to making any modification. This is the only way to determine whether modified components are suitable for use with our products.

---

## 1.12 Maintenance, repair

**DANGEROUS ELECTRICAL VOLTAGE**

Prior to any maintenance work - unless described otherwise - the system must always be switched off!

In the event of necessary measurement or test procedures on the active system, these have to be performed by skilled electrical personnel.

In any case, suitable insulated tools must be used!

**DANGEROUS ELECTRICAL VOLTAGE**

If you need to open the MF inverter housing, disconnect the system from supply and wait at least 5 minutes before you open the housing so as to ensure that the MF inverter is de-energized.

**DANGER**

Danger of life through inappropriate EMERGENCY-STOP facilities! EMERGENCY-STOP facilities must be operative in all modes of the system. Releasing the EMERGENCY-STOP facility must by no means result in an uncontrolled restart of the system! First check the EMERGENCY-STOP circuit, then switch the unit on!

**DANGER**

Danger of explosion of batteries!

Do not forcefully open batteries, do not attempt to charge, solder or incinerate the battery.

Empty batteries should always be replaced by new ones!

The applicable regulations on the disposal of empty batteries or accumulators must be observed.

**DANGER**

The right to perform repair/maintenance work on the components of the medium-frequency inverters is reserved to the BOSCH service department or to repair/maintenance units authorized by BOSCH!

**CAUTION**

Only use spare parts approved by BOSCH!

## 1.13 Working safely

---

**DANGER**

During operation of the welding equipment welding splashes are to be expected! They may cause eye injuries or burns.

Therefore:

- D wear protective goggles
  - D wear protective gloves
  - D wear flame-retardant clothes
- 

**DANGER**

Danger of injury from sheet metal edges and danger of burns from weld metal!

Therefore: - wear protective gloves

---

**DANGER**

In the environment of resistance welding systems, magnetic field strengths have to be expected which are above the limit values specified in VDE 0848 Part 4. Especially if manual guns are used, the limit values for extremities may be exceeded.

In cases of doubt, you should measure the field strength and take additional measures to ensure safety and health at work.

---

**CAUTION**

The strong magnetic fields occurring in the resistance welding process may cause permanent damage to wrist watches, pocket watches, or cards with magnetic stripes (e.g. EC cards).

Therefore, you should not carry any such items on you when working in the immediate vicinity of the welding equipment.

---

## 1.14 CE conformity

---



### CAUTION

The CE mark is valid for the medium-frequency inverter only with respect to the Low-Voltage Directive. Concerning EMC, it is always necessary to consider the entire application.

The CE mark for MF inverter - welding transformer combinations refers to industrial applications.

For other combinations/applications, the certificate must be derived from the above, or a new certificate must be issued, if necessary, by the line designer / user.

---

## 2 Setup

### 2.1 Features

- D Integrated control functionality for medium frequency welding
- D Integrated welding control
- D Flexible parallel and/or serial I/O interfaces
- D Fieldbus interfaces for communication
- D Integrated control and monitoring functions
- D Control functionality separate from monitoring functionality
- D Air or water cooled
- D Less cabling required due to system component integration
- D Functionality designed for welding quality optimization
- D Easily integrated into a portable welding box system (SCHWEISSKOFFER)
- D BOS-5000 operator interface provides for easy programming, operation and diagnostics



*PSI 6000 medium frequency inverter series with PSG 3000 weld transformers*

## 2.2 Modules and components

The PSI 6000 medium-frequency inverters serve to control the PSG 3000 welding transformers.

Integrated features:

- D the weld timer (central processing unit, CPU)
- D one slot for the type-specific I/O interface
- D one slot for the field bus module for programming (optional)
- D one slot for retrofitting a quality module (optional)

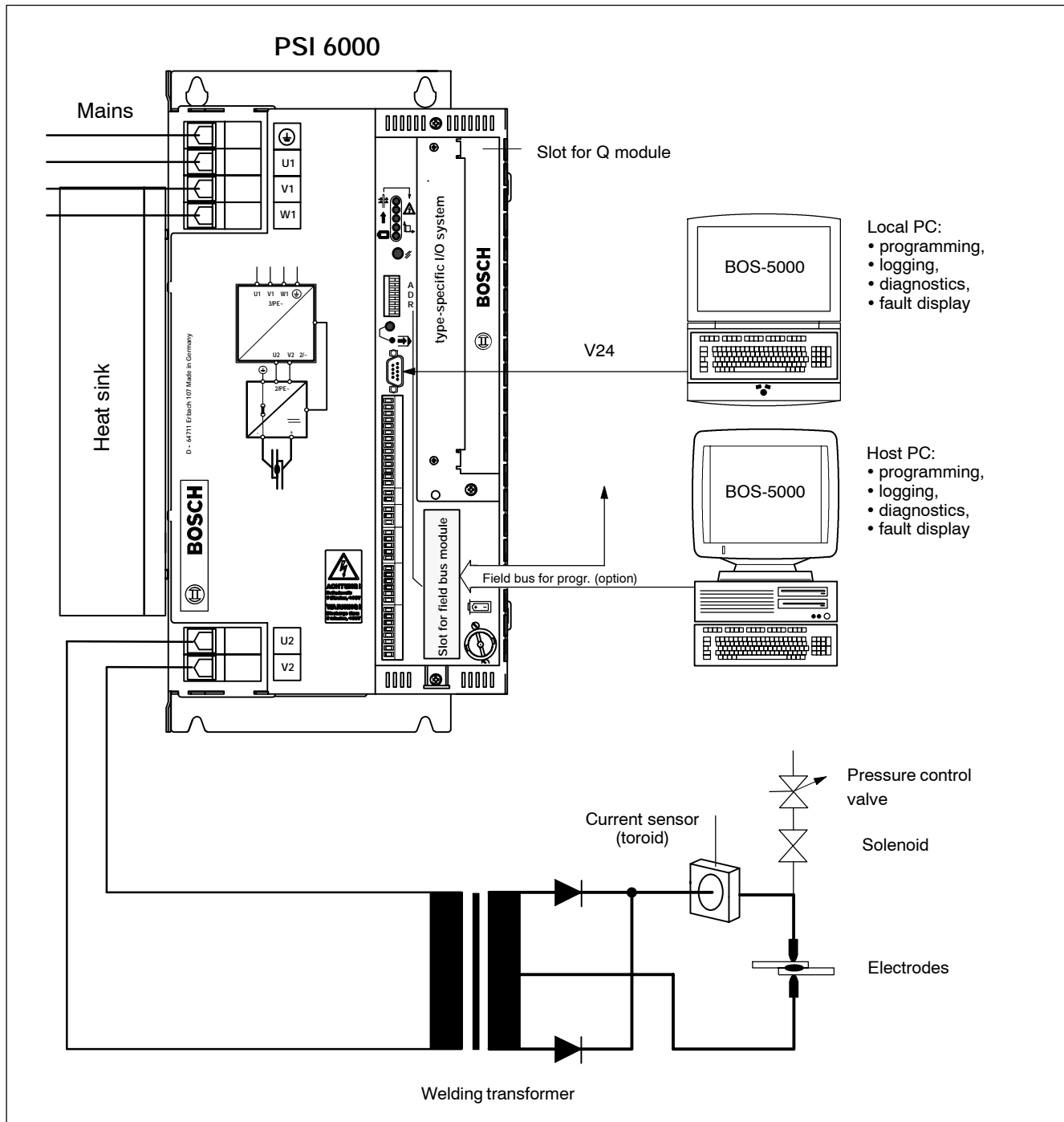

Setup for welding

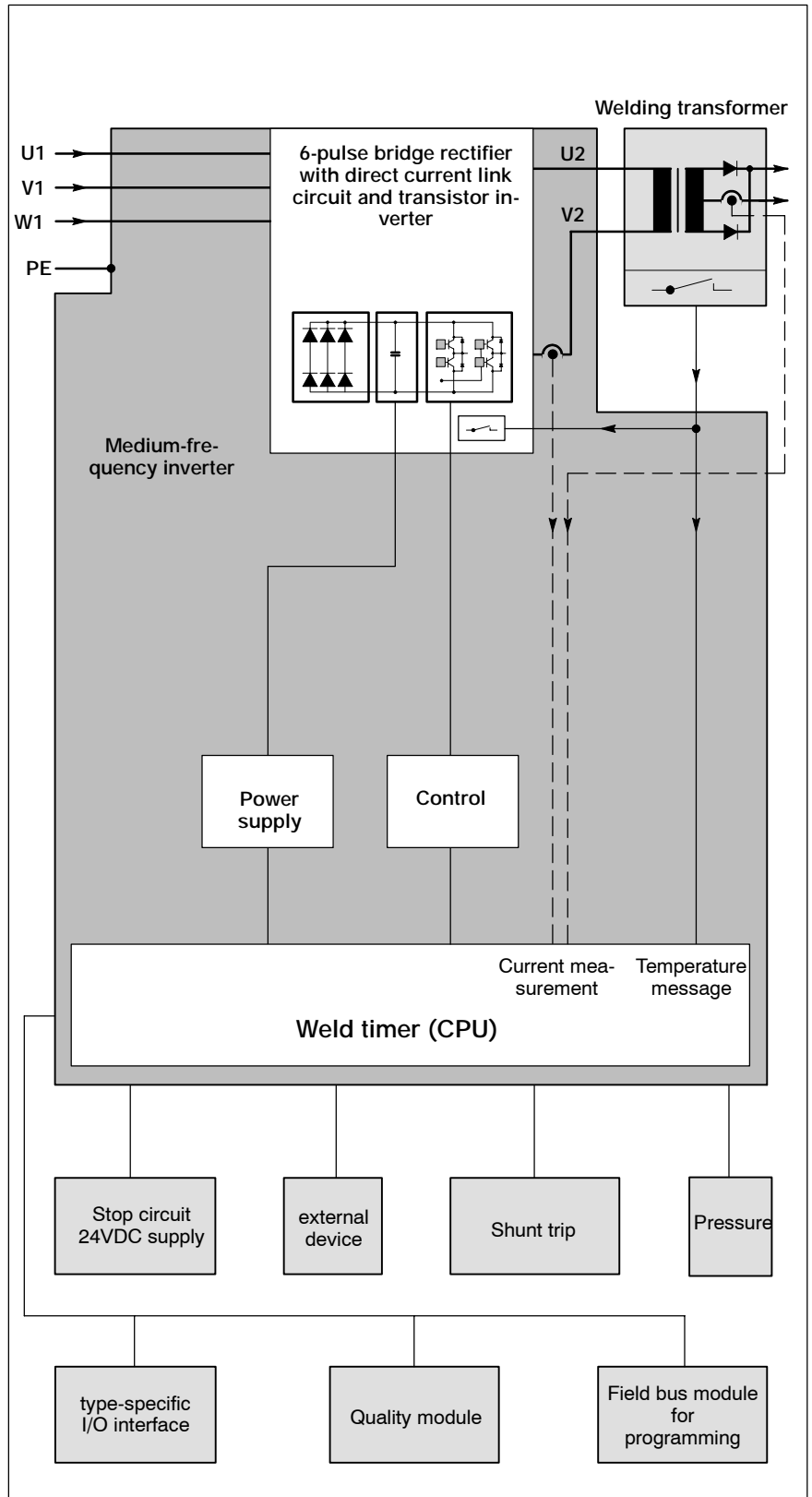

Block diagram of a medium-frequency inverter

## 2.3 Function

The medium-frequency welding system (MF welding system) is designed for direct current resistance welding. Its key components are the PSI 6000 medium-frequency inverter and the PSG 3000 MF welding transformer.

The figure below shows the basic functional design of the MF welding process.

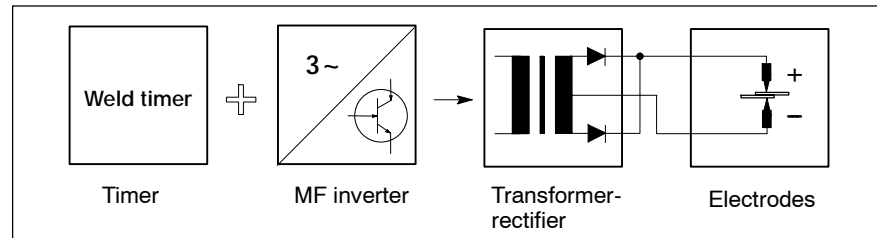

*Basic functional design of the 1 kHz MF welding process*

The 50 / 60 Hz mains AC is first rectified by a bridge connected rectifier (B6 connection). The direct current generated connects a transistorized H-bridge alternately to the PSG 3000 welding transformer at a frequency of 1 kHz. In secondary circuit, the transformer rectifies the welding current.

The intensity of the welding current can be controlled by adjusting the pulse width. The welding current is measured either with a current sensor integrated in the secondary circuit of the PSG 3000 welding transformer or, in the case of a welding transformer without a current sensor, with a primary current ammeter integrated in the MF inverter.

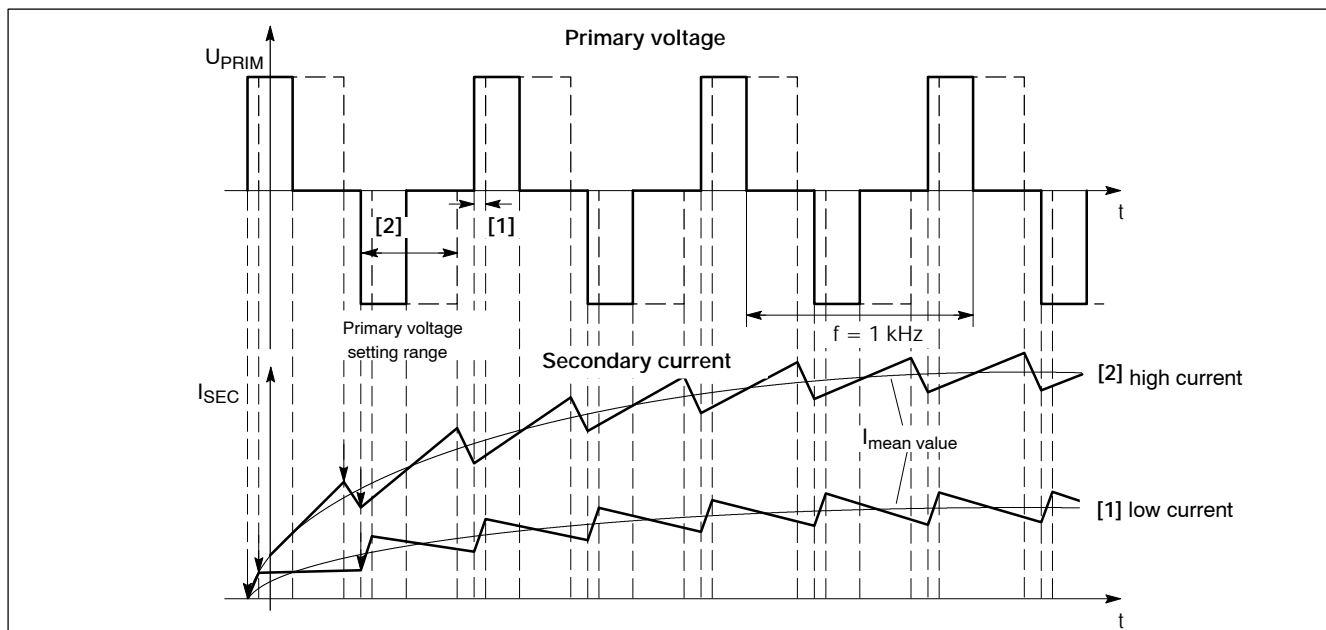

*Primary and secondary voltages for medium-frequency welding*

The welding current output of the welding transformer or, resp., the primary current multiplied by the transformation ratio are measured and processed in the welding control for monitoring and control purposes.

## 2.4 Monitoring

In order to ensure high operational reliability, various monitoring functions are incorporated in the PSI 6000 medium-frequency inverter.

There is a thermostatic switch to signal any overload on the PSG 3000 welding transformer and/or the MF thyristor unit to the weld timer.

The weld timer will then output a "Thyristor unit fault" message.

When the fault has been cleared, the error message is reset as follows:

- D with the reset button on the weld timer front panel
- D by an input signal for acknowledgement (type-specific)
- D by an input on the BOS-5000 operator interface
- D by an input on the Bosch operator terminal (BT)

## 2.5 Advantages and benefits of medium-frequency welding

The PSI 6000 medium-frequency inverters supply an MF output voltage and DC welding current. As a result, the welding process can be controlled more thoroughly and faster and becomes more steady. The "good" welding range becomes larger.

The medium-frequency welding current is clocked at 1 kHz. The current regulation system is faster and more precise compared to 50 Hz welding.

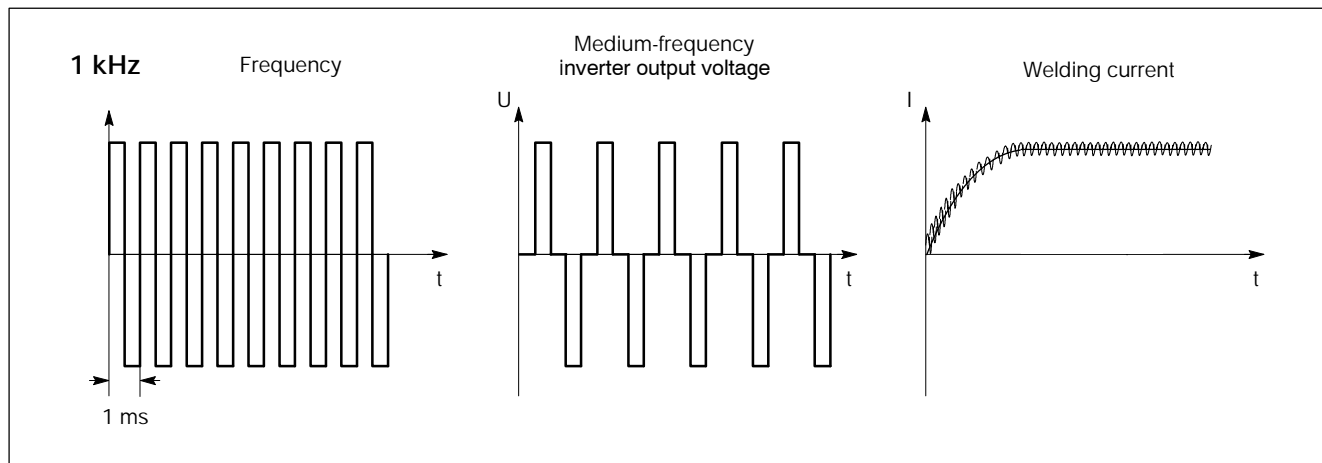

Medium-frequency welding

- D A direct current flows in the secondary welding circuit of the transformer. As a result, the inductive resistance of the secondary window loses its influence on the welding current with different immersion depths of the electrode gun into the workpiece.
- D The weight of the welding transformer is reduced. Due to the higher operating frequency, the iron content required as well as the volume are reduced while the performance data is maintained.
- D The more steady welding current without any gaps and the possibility of weld time variation in ms intervals allow for the metered application of energy to the spot weld and a steady growth of the spot.
- D Longer electrode life.
- D Good results are obtained for welding aluminium and galvanized sheets.
- D Especially suitable for 3-sheet welding, very thin sheets and fine spot applications.
- D Fewer welding splashes.
- D Medium-frequency welding with current control improves the quality of the spot weld.  
The welding system with constant-current control (KSR) compensates the changes in sheet resistance within the weld time and helps to obtain a constant welding result.

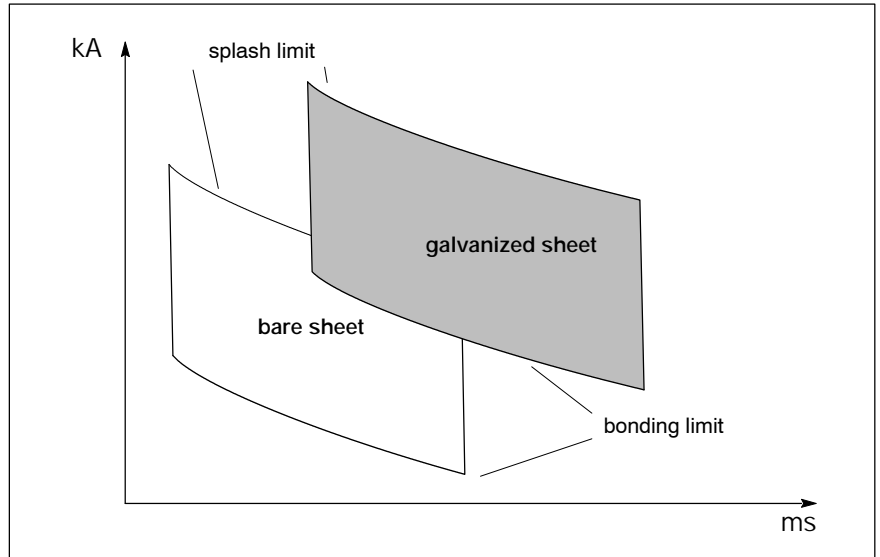

Welding of different sheet types, conventional 50/60 Hz weld

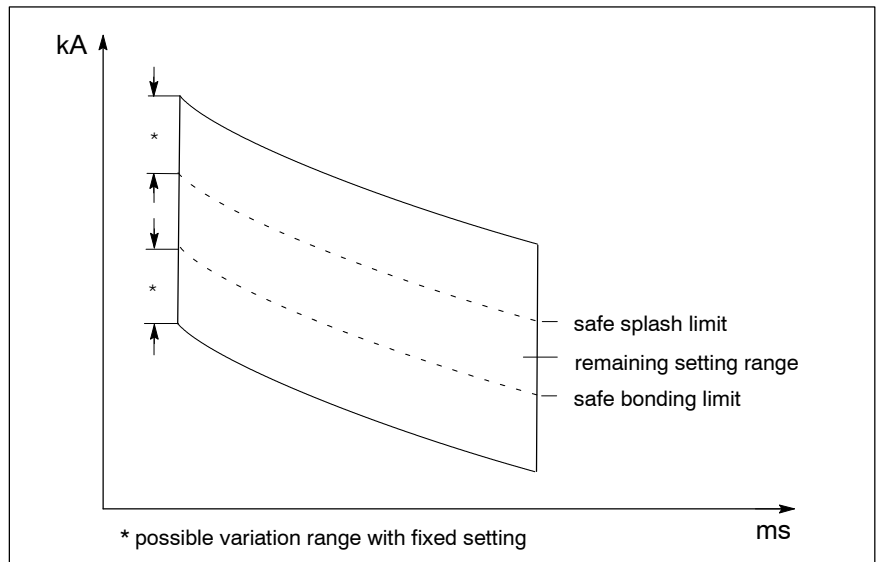

Welding of galvanized sheet types with 1 kHz welding process

Notes:

### 3 Notes on Rating

The load capability of an MF inverter is always predefined by the type designation indicating the specific maximum welding transformer rating.



#### CAUTION

Overloading may cause damage to the MF inverter!  
Always check the actual load applied on the MF inverter! Any and all warranty excluded in case of damage caused by overload.

To check the actual load, use the load diagram. It shows the  
 D output currents ( $I_{\text{PRIM}}$  in A) relative to  
 D the duty cycle (ED in %) at  
 D maximum ambient temperature (in °C)  
 that can be switched by the PSI 6000 MF inverter.

The weld time  $t_s$  and the overall weld cycle duration  $t_{\text{sp}}$  must be known to determine the duty cycle.

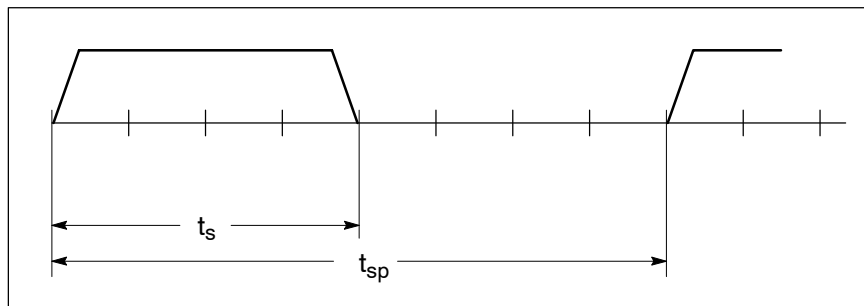

*Weld time and overall weld cycle duration*

The duty cycle is computed as follows:

$$ED = \frac{t_s}{t_{\text{sp}}} \cdot 100\%$$

Example: In the graph shown above, the weld time is 4 ms and the weld cycle duration is 8 ms.  
This results in a duty cycle ED = 50%.

$$ED = \frac{4 \text{ ms}}{8 \text{ ms}} \cdot 100\% = 50\%$$

**Note:** If different weld times or overall weld cycle times occur on a machine, the longest weld time and the shortest overall weld cycle time (to be determined, if required, by adding the longest weld time to the shortest cool time) must be used for calculating the duty cycle!

When you have calculated the duty cycle, you can use load diagrams to verify the proper selection of the MF inverter.

### 3.1 Load diagrams

Various types of semiconductors are used as power breakers in the welding systems. Generally, semiconductors have an almost unlimited life if used in accordance with the specifications.

Unfortunately, however, the relatively large semiconductor chips have to sustain mechanical stress due to thermal loads. This mechanical stress may reduce semiconductor life.

Solder fatigue and defective wire bonds have been reported in literature as factors affecting the life of IGBTs (used as power breakers in the PSI 6000 MF inverters).

As regards the weld diodes of the MF transformers (PSG 3000), the loads acting on these large silicon wafers may have the effect that crystal impurities as they are found in every silicon crystal may lead to diode failure.

Semiconductor manufacturers state life characteristics for calculation purposes. There, varying with the junction temperature gradient, the number of temperature cycles available until the calculated end of the semiconductor service life is stated. Every weld spot represents one temperature cycle.

We have taken these conditions into account in the rating of our systems.

Our PSI 6000 load diagrams also include peak current curves indicating the calculated service life in each case.

The temperature gradient, which – among other contributing factors – depends on the welding current, secondary resistance, weld time and ambient temperature is taken into account in the service life calculation. Because our curves shown are based on 45°C ambient temperature, while 25°C would be a realistic assumption, you may expect a service life three times as long as the one stated.

On principle, service life is extended with the lower temperatures achieved with water cooling as compared to air cooling. However, depending on the application, the temperature may drop more steeply during the cooling time after a weld spot due to the superior cooling capacity of water, which in turn shortens the life time due to the higher temperature gradient. However, it is possible to have the cooling water running only during the weld time, which also allows you to save water.

If you need further information in respect of any specific application, please contact us.

The load diagrams show the inverter output currents or, respectively, the primary currents of the welding transformers.

To determine secondary currents, multiply the primary currents by the transformation ratio.

## 4 Commissioning



### DANGEROUS ELECTRICAL VOLTAGE

Danger of life in case of contact with live parts!

Upon commissioning, the MF inverter is energized!

If the medium-frequency inverter housing is to be opened, switch off the system and wait for at least 5 minutes until the medium-frequency inverter is de-energized.

---



### CAUTION

Cooling!

Please make sure that there is sufficient cooling capacity.

In the case of water cooled MF inverters, ensure that the cooling water inlet connection is turned on and check the water temperature.

Any and all warranty excluded in case of non-compliance.

---

- D Check the mechanical system of the welding outfit.
- D Check the electrical installation.
- D Check the auxiliary equipment:
  - D pneumatic system
  - D cooling water or cooling system.
- D Check the operability of the emergency devices.
- D **Cutting in the MF inverter:**
  - D Apply mains voltage.
  - D The MF inverter starts working. After approx. 10 s, the DC link voltage is charged at full voltage and the green "Power" LED on the front panel of the weld timer (CPU) lights up.
- D Check power supply and 24 V DC supply.
- D Check peripheral I/O signals:
  - D sensor signals,
  - D communication with other weld timers.
- D Check weld programs (for programmed current values and weld times).
- D **Cutting off the MF inverter:**
  - D When the power supply is switched off, the bridge rectifiers are blocked and the DC link voltage is discharged.
  - D Verify the safe isolation from supply.

Notes:

## 5 Maintenance

---



### DANGEROUS ELECTRICAL VOLTAGE

All maintenance work must be carried out by skilled electricians in compliance with the valid safety regulations, the mains voltage and the maximum current input values of the individual system components.

Prior to connecting an MF inverter, the following must be strictly observed:

- D Power OFF.
  - D Provide a safeguard to prevent unintentional reclosing.
  - D Verify the safe isolation from supply.
  - D Connect to earth and short circuit.
  - D Cover up or safeguard all live parts.
- 



### DANGEROUS ELECTRICAL VOLTAGE

Prior to any maintenance work - unless described otherwise - the system must always be switched off!

If the system had been active shortly before, wait until the system is totally de-energized before starting the maintenance work (e.g. because of charged capacitors, etc.). For the duration of the maintenance work the system must always be protected against re-closing.

In the event of necessary measurement or test procedures at the active system, the applicable safety and accident prevention regulations must be strictly observed. In any case, suitable insulated tools must be used!

If the medium-frequency inverter housing is to be opened, switch off the system and wait for at least 5 minutes for the medium-frequency inverter to de-energize.

**Danger of life through inappropriate EMERGENCY-STOP facilities!**  
EMERGENCY-STOP facilities must be operative in all modes of the system. Releasing the EMERGENCY-STOP facility must by no means result in an uncontrolled restart of the system!

**Danger of explosion of batteries!**

Batteries must not be opened forcefully, recharged, soldered at the cell body or thrown into fire!

Replace empty batteries with new ones only!

---

**DANGEROUS ELECTRICAL VOLTAGE**

The right to perform repair/maintenance work on the timer components is reserved to the BOSCH service department or to repair/maintenance units authorized by BOSCH!

Only use spare parts/replacement parts approved by BOSCH!

Run-down batteries or accumulators must be disposed of according to regulations.

---

- D Check connections and terminals of all connecting cables for tight fit at regular intervals. Check all cables for damage.
- D Check or replace battery at regular intervals.
- D Clean the air cooler.
- D Maintenance of cooling water circuit:  
Check for leaks, corrosion and moisture condensation.

## 6 Malfunction

Although the design of the MF inverters is quite rugged, malfunctions may occur in a few exceptional cases, e.g. for the following reasons:

- D incorrect electrical connection or mains voltage surges,
- D insufficient cooling or overload on the MF thyristor unit may trigger the thermal detector,
- D current parameters set are higher than the maximum current permitted or the monitoring values.

In case of failure, the green LED "Ready" ↑ on the front panel of the weld timer unit goes out. Further information is provided by the diagnostics function, the error message display on the BOS-5000 operator interface, or a message on the BT Bosch operator terminal.



### DANGEROUS ELECTRICAL VOLTAGE

Danger of life in case of contact with live parts!

Disconnect the system from the mains supply before trouble shooting or replacing a fuse!

### Thermal detector response

The MF thyristor unit contains an NTC thermistor detector, which transmits a message to the integrated weld timer if the temperature reaches or rises above  $\geq 65^{\circ}\text{C}$  ( $+5^{\circ}\text{C}$ )

If this happens, the weld timer blocks any further sequence.

The green LED "Ready" on the front panel of the weld timer unit goes out and the message "Thyristor unit temperature" is output.

Possible causes	Corrective action
Dirt accumulation in heat sink	Clean out the heat sink
Excessive ambient temperature	Check for sufficient convection. Checking external forced ventilation may be required.
Capacity of MF thyristor unit too low	Compute duty cycle and check selection using load diagram (see section "Notes on Rating").
No or insufficient cooling water flow	Check cooling water inlet and/or temperature.

Notes:

## 7 Type overview

### 7.1 Features

#### PSI 6025.XXX L1

- D Medium-frequency inverter 0.5 to 7 kA
- D Air cooling
- D Integrated control function
- D Rated voltage 400 to 480 Volt, 50/60 Hz
- D Rated current 20 A (continuous thermal current)
- D Preferably for connecting welding transformer
  - D PSG 3025.00 A

#### PSI 6100.XXX L1/W1

- D Medium-frequency inverter 3 to 20 kA
- D Air cooling (L1), water cooling (W1)
- D Integrated control function
- D Rated voltage 400 to 480 Volt, 50/60 Hz
- D Rated current 110 A (continuous thermal current)
- D Preferably for connecting welding transformers
  - D PSG 3050.00 A
  - D PSG 3050.10 A
  - D PSG 3075.10 A
  - D PSG 3100.00 A

#### PSI 6100.XXX L2/W2

- D Medium-frequency inverter 3 to 20 kA
- D Rated voltage 480 to 690 Volt, 50/60 Hz
- D Other than that like PSI 6100.XXX L1/W1

**PSI 6200.XXX W1**

- D Medium-frequency inverter 9 to 54 kA
- D Water cooling
- D Integrated control function
- D Rated voltage 400 to 480 Volt, 50/60 Hz
- D Rated current 220 A (continuous thermal current)
- D Preferably for connecting welding transformers
  - D PSG 3100.00 A
  - D PSG 3200.00 A
- D Seam-welding functionality also available

**PSI 6200.XXX W2**

- D Medium-frequency inverter 9 to 54 kA
- D Rated voltage 480 to 690 Volt, 50/60 Hz
- D Other than that like PSI 6200.XXX W1

**PSI 6300.XXX L1/W1**

- D Medium-frequency inverter 6 to 36 kA
- D Air cooling (L1), water cooling (W1)
- D Integrated control function
- D Rated voltage 400 to 480 Volt, 50/60 Hz
- D Rated current 110 A (continuous thermal current)
- D Preferably for connecting welding transformers
  - D PSG 3100.00 A

**PSI 6300.XXX L2/W2**

- D Medium-frequency inverter 6 to 36 kA
- D Air cooling (L2), water cooling (W2)
- D Integrated control function
- D Rated voltage 480 to 690 Volt
- D Rated current 110 A (continuous thermal current)
- D Preferably for connecting welding transformers
  - D PSG 3100.00 A

**PSI 6500.XXX W1**

- D Medium-frequency inverter 9 to 120 kA with PSG 3100
- D Water cooling
- D Integrated control function
- D Rated voltage 400 to 480 Volt, 50/60 Hz
- D Rated current 660 A (continuous thermal current) with cubicle cooling unit
- D Preferably for connecting welding transformers
  - D PSG 3100.00 A
  - D PSG 3200.00 A
- D Seam-welding functionality also available

## 8 PSI 6025.XXX L1

### 8.1 Explanation of drawings

The following drawings show the

- D front plate with modules of the MF inverter
  - D integrated weld timer
  - D slot for the parallel, serial or fieldbus I/O interface
  - D slot prepared for retrofitting a quality module
  - D slot for fieldbus interface for programming (optional)
- D technical data
- D dimensions and mounting options
- D mains connection
  - D connection of the PSG 3000 welding transformer
- D load diagram
- D accessories and part numbers

**Note: Drawings do not include heat sinks.**

## 8.2 PSI 6025.XXX L1 front panel

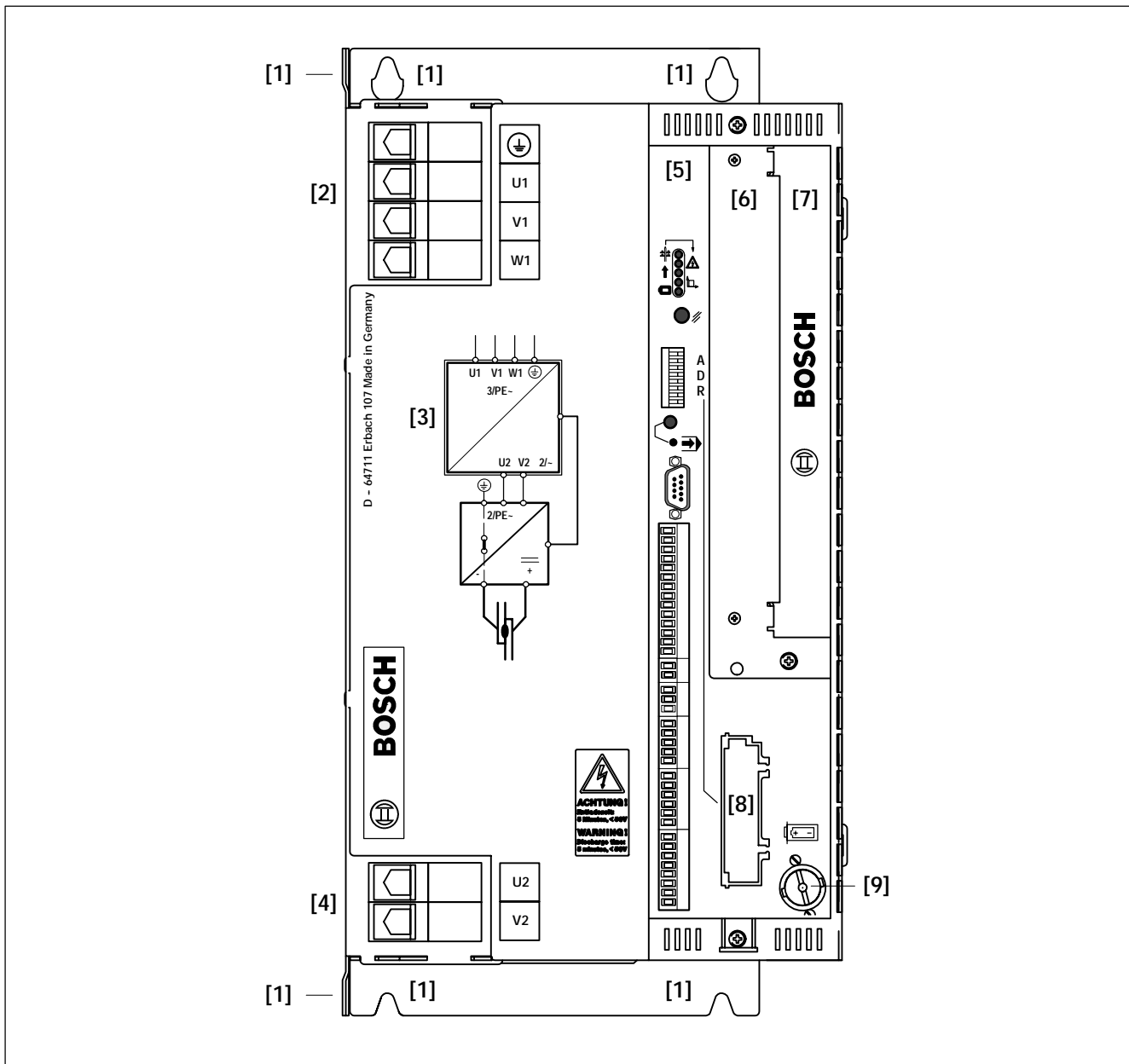

PSI 6025.XXX L1 front panel

- [1] M6 mounting options
  - D rear panel
  - D left side panel (mounting cutout required)
- [2] mains supply connection
- [3] MF inverter symbol
- [4] PSG 3000 welding transformer connection
- [5] integrated weld timer
- [6] slot for type-specific I/O interface:
  - D parallel I/O interface
  - D serial I/O interface
  - D fieldbus I/O interface

- [7] slot for retrofitting a quality module
- [8] slot for fieldbus interface for programming
- [9] battery compartment

## 8.3 Technical data, PSI 6025.XXX L1

Type	3-phase MF inverter, module designed for recessed mounting
Weld timer	integrated
I/O interface	Slot for parallel, serial or fieldbus interface
Quality module	Slot prepared for retrofitting
Degree of protection	IP 20; designed for modular enclosure or for installation in switchgear cabinets with IP 54
Inverter ambient temperature	max. 55° C
Heat sink	air, max. 45° C, temperature controlled; without fan cowl
Temperature monitoring	integrated
Storage temperature	-25° C to +70° C
Corrosion	The ambient air must be free of acids, caustic solutions, corrosive agents, salts and metal vapors of any major concentration
Humidity	Humidity class F as per DIN 40040; 20° C at 90% relative humidity; 40° C at 50% relative humidity (as per VDE 0113); Moisture condensation on the MF inverters must be prevented.
Air pressure	Any within a range of up to 2000 m above sea level
Line voltage connection grounded TN or TT system	400 V -20% to 480 V +10%; 50/60 Hz
Nominal system current; max. continuous thermal current	20 A
Max. output current	100 A
Max. secondary current; depending on the transformer used	7 kA (PSG 3025)
Voltage supply; Weld timer CPU; I/O interface	24 V DC; min. 19 V DC up to max. 30 V DC as per EN 61131-2, (external power supply), or, alternatively, power supply from the weld current system (internal power supply)
Clock frequency	1 kHz
Overvoltage protection	MOV; Metal Oxide Varistor
Electrical connection, mains supply and transformer	via box terminal; max. 50 mm <sup>2</sup>
Wire range	16 mm <sup>2</sup>
Basic switchgear cabinet loss	69 W
Max. ventilating and cooling loss dissipated via external air-cooler	40 W
Switchgear cabinet loss at max. power	100 W
Weight	approx. 15 kg
Mounting position	vertical or with its back on mounting plate

8.4 Dimensioned drawing, PSI 6025.XXX L1

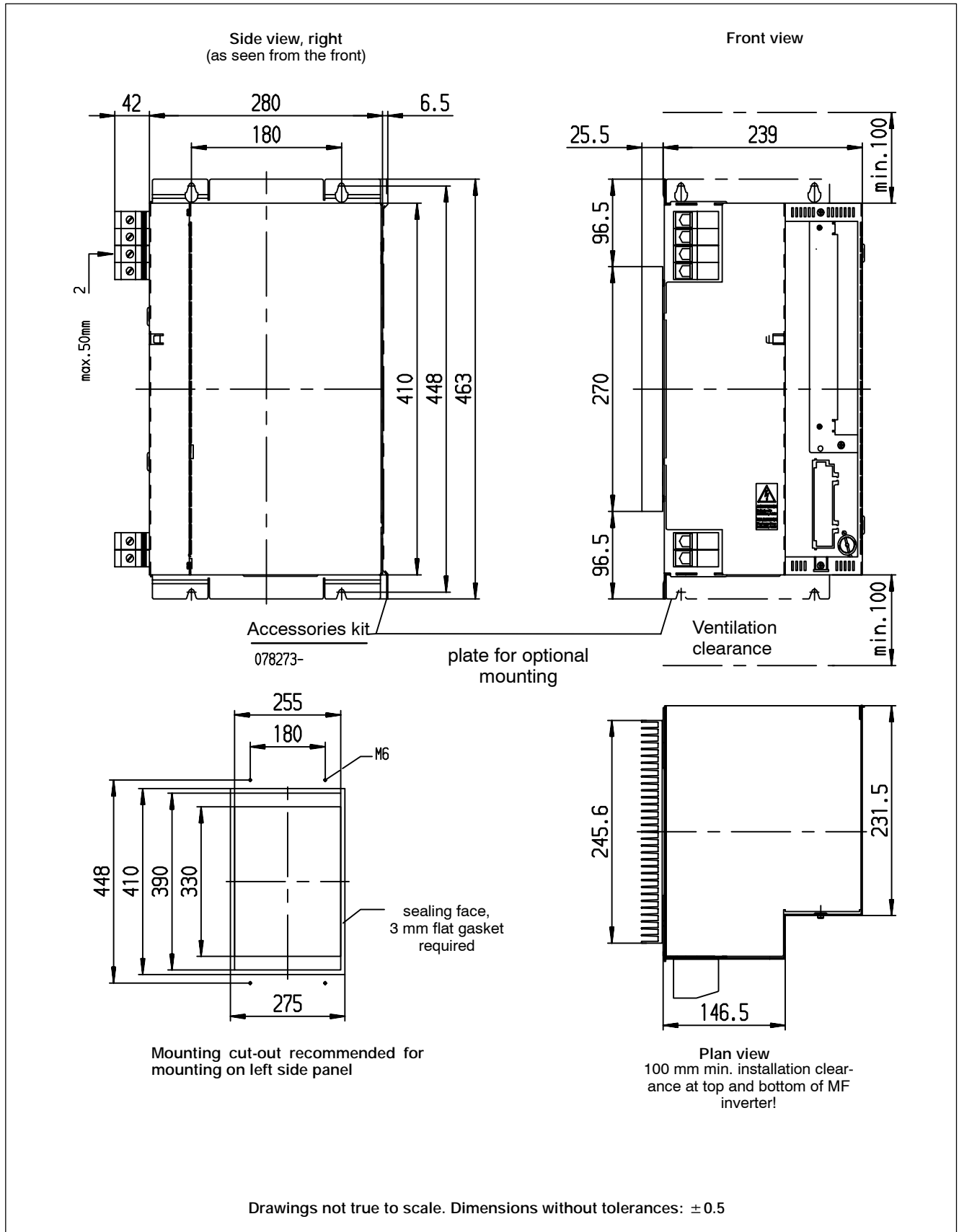

Dimensioned drawing, PSI 6025.XXX L1

## 8.5 Electrical connection, PSI 6025.XXX L1

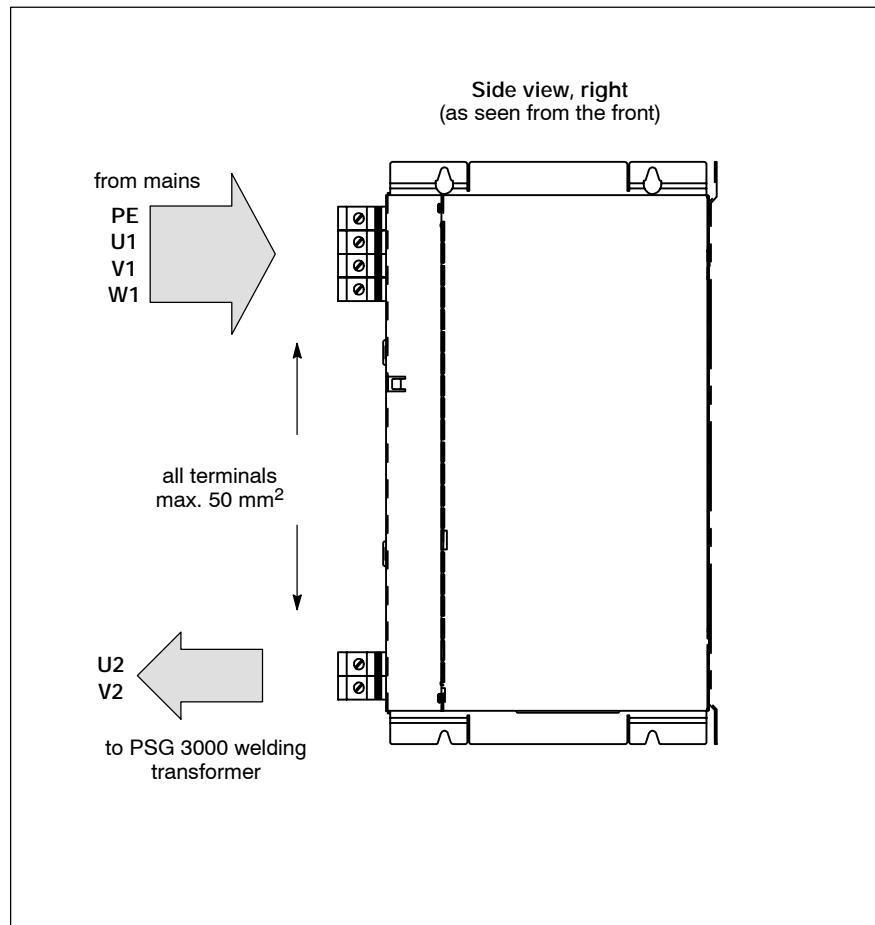

*Electrical connection, PSI 6025.XXX L1*

**Note:** For the connections of the various control functions, please see the respective manuals "PSI 6000, Control and I/O Level Description".

8.6 Load diagram, PSI 6025.XXX L1

Note: For a general description of load diagrams, see Section 3.1

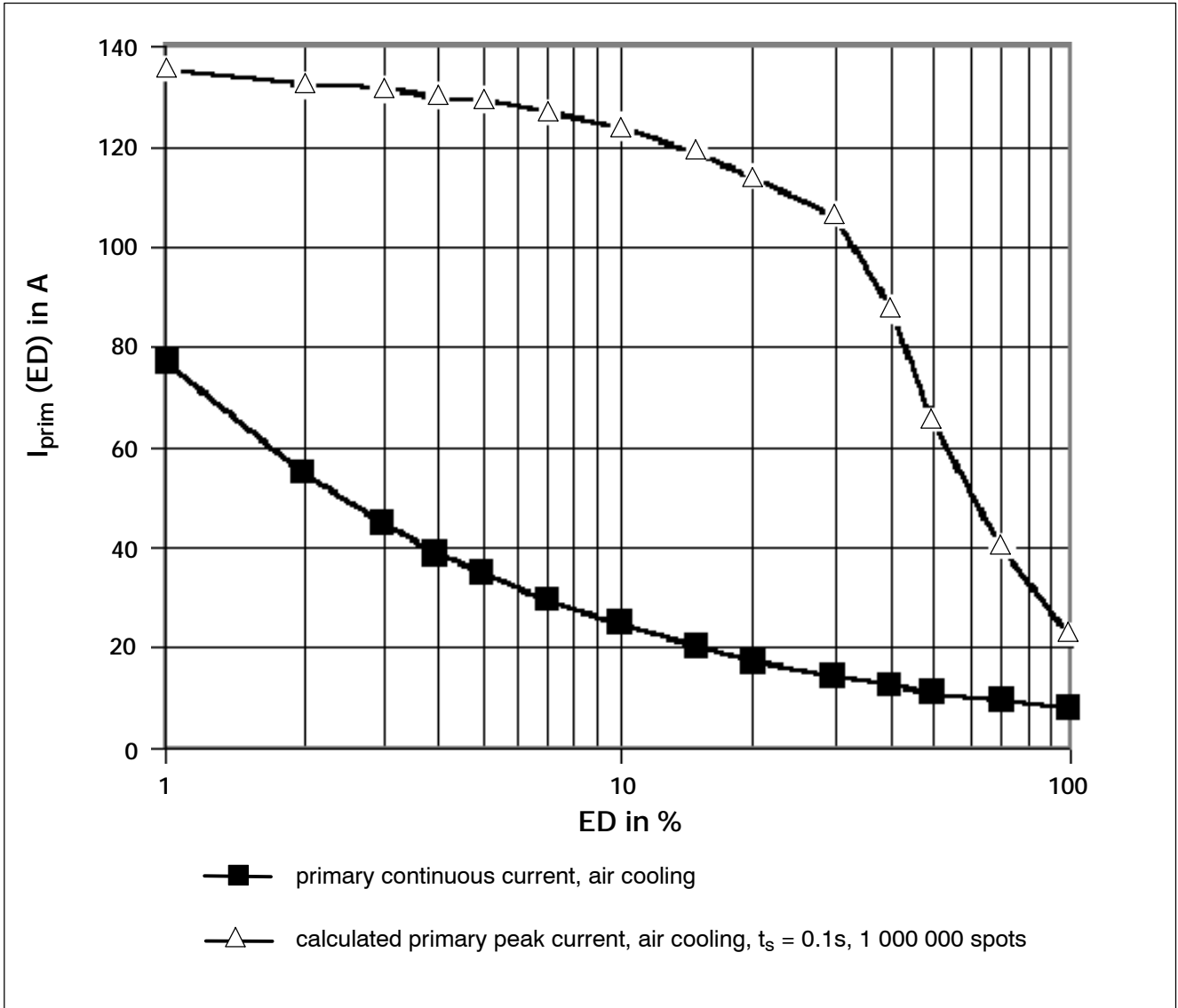

Load diagram, PSI 6025.XXX L1



- D For PSG 3000 welding transformers, see Technical Information, PSG 3000 MF Welding Transformers, part no. 1070 080 087.
- D For I/O module, see Technical Information, PSI 6000, Control and I/O Level Description.
- D For insertable profiles for electric connection, see the section on ordering.

## 8.8 Ordering, PSI 6025.XXX L1

Designation	Part no.
PSI 6025.100 L1 medium-frequency inverter	1070 080 997

Not included in shipment:

Designation	Part no.
Insertable profile for pin connectors on small wire sizes, line connection and welding transformer connection	1070 918 779
Accessories kit for PSI 6025.XXX L1 mounting	1070 078 273
SSR 81.00 current sensor without fixing device, in the form of a toroid coil; 55 mm internal diameter; with 5-pole sleeve terminal	1070 048 099
SSR 81.01-08 current sensor with fixing device; e.g. for various electrode makes	on request
Mating connector for SSR 81.0X current sensor	1070 913 489
Sensor cable LiYCY 2x2x0,75 mm <sup>2</sup> shielded	1070 913 494

## 9 PSI 6100.XXX L1/L2/W1/W2

### 9.1 PSI 6100.XXX L1/L2/W1/W2 overview

- D PSI 6100.XXX L1 :
  - D air-cooled
  - D 400 V -20% to 480 V +10%, 50/60 Hz
- D PSI 6100.XXX L2 :
  - D air-cooled
  - D 480 V -20% to 690 V +10%, 50/60 Hz
- D PSI 6100.XXX W1 :
  - D water-cooled
  - D 400 V -20% to 480 V +10%, 50/60 Hz
- D PSI 6100.XXX W2 :
  - D water-cooled
  - D 480 V -20% to 690 V +10%, 50/60 Hz

### 9.2 Explanation of drawings

The following drawings show the

- D front plate with modules of the MF inverter
  - D integrated weld timer
  - D slot for the parallel, serial or fieldbus I/O interface
  - D slot prepared for retrofitting a quality module
  - D slot for fieldbus interface for programming (optional)
- D technical data
- D dimensions and mounting options
- D mains connection
  - D connection of the PSG 3000 welding transformer
- D load diagram
- D accessories and part numbers

. **Note: No heat sinks or water connections shown on drawings.**

## 9.3 PSI 6100.XXX L1/L2/W1/W2 front panel

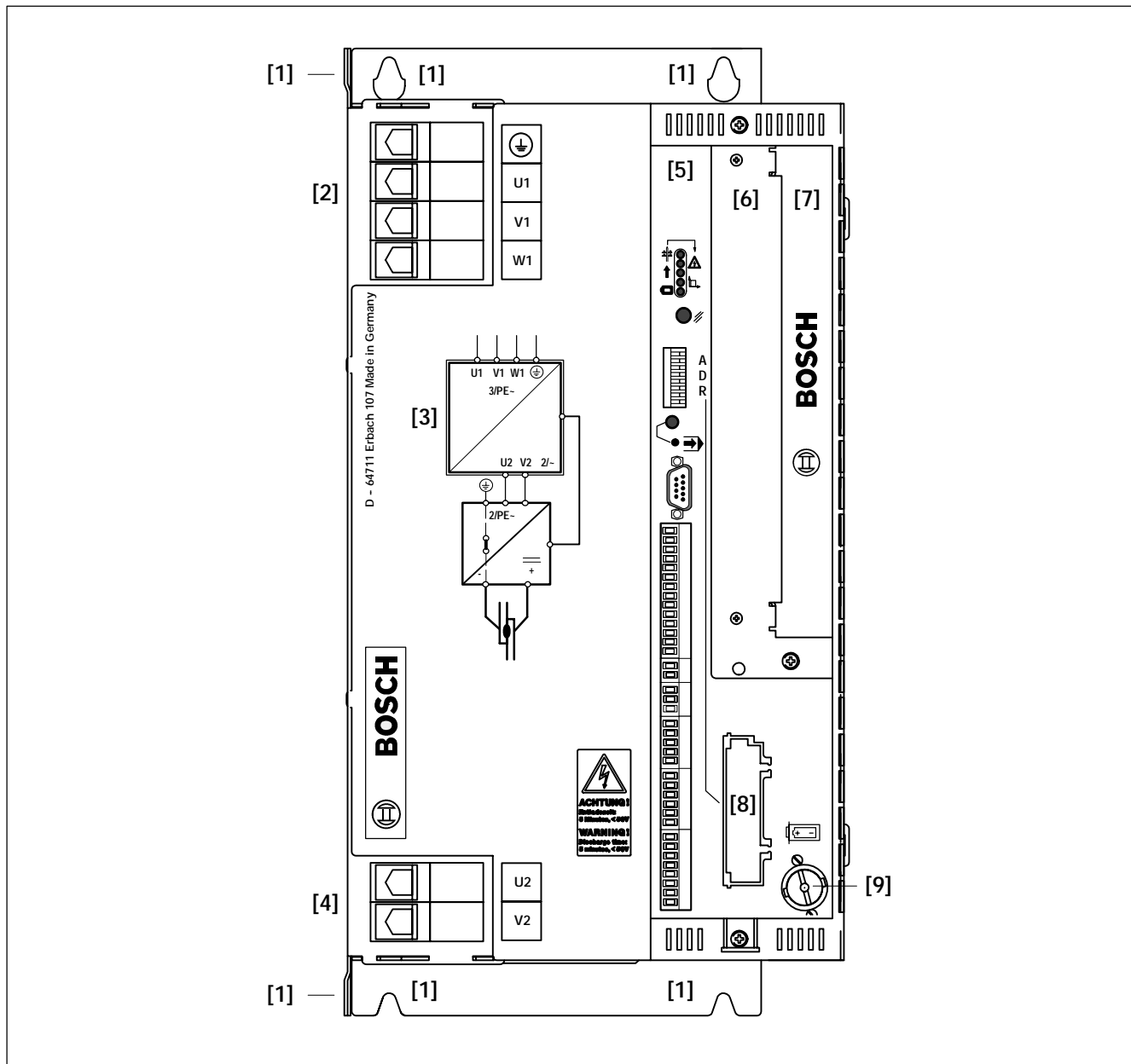

PSI 6100.XXX L1/L2/W1/W2 front panel

- [1] M6 mounting options
  - D rear panel
  - D left side panel (mounting cutout required)
- [2] mains supply connection
- [3] MF inverter symbol
- [4] PSG 3000 welding transformer connection
- [5] integrated weld timer
- [6] slot for type-specific I/O interface:
  - D parallel I/O interface
  - D serial I/O interface
  - D fieldbus I/O interface

- [7] slot for retrofitting a quality module
- [8] slot for fieldbus interface for programming
- [9] battery compartment

## 9.4 Technical data, PSI 6100.XXX L1/L2/W1/W2

Type	3-phase MF inverter, module designed for recessed mounting
Weld timer	integrated
I/O interface	Slot for parallel, serial or fieldbus interface
Quality module	Slot prepared for retrofitting
Degree of protection	IP 20; designed for modular enclosure or for installation in switchgear cabinets with IP 54
Inverter ambient temperature	max. 55° C
Cooling	L1/L2: air, max. 45° C with Bosch fan cowl, temperature-controlled through inverter W1/W2: water, 4 l/min; max. 30° C
Temperature monitoring	integrated
Storage temperature	-25° C to +70° C
Corrosion	The ambient air must be free of acids, caustic solutions, corrosive agents, salts and metal vapors of any major concentration
Humidity	Humidity class F as per DIN 40040; 20° C at 90% relative humidity; 40° C at 50% relative humidity (as per VDE 0113); Moisture condensation on the MF inverters must be prevented.
Air pressure	Any within a range of up to 2000 m above sea level
Line voltage connection grounded TN or TT system	L1/W1: 400 V -20% to 480 V +10%; 50/60 Hz L2/W2: 480 V -20% to 690 V +10%; 50/60 Hz
Nominal system current; max. continuous thermal current	110 A
Max. output current	400 A
Max. secondary current; depending on the transformer used	20 kA (PSG 3100)
Voltage supply; Weld timer CPU; I/O interface	24 V DC; min. 19 V DC up to max. 30 V DC as per EN 61131-2, (external power supply), or, alternatively, power supply from the weld current system (internal power supply)
Clock frequency	1 kHz
Overvoltage protection	MOV; Metal Oxide Varistor
Electrical connection, mains supply and transformer	via box terminal; max. 50 mm <sup>2</sup>
Wire range	35 mm <sup>2</sup>
Basic switchgear cabinet loss	L1/W1: 69 W L2/W2: 100 W

Max. cooling losses	L1/L2: 360 W W1: 420 W W2: 500 W
Switchgear cabinet loss at max. power	L1: 170 W L2: 200 W W1: 110 W W2: 140 W
Weight	L1: approx. 20 kg L2: approx. 21 kg W1: approx. 25 kg W2: approx. 26 kg
Mounting position	vertical or with its back on mounting plate

9.5 Dimensioned drawing, PSI 6100.XXX L1/L2

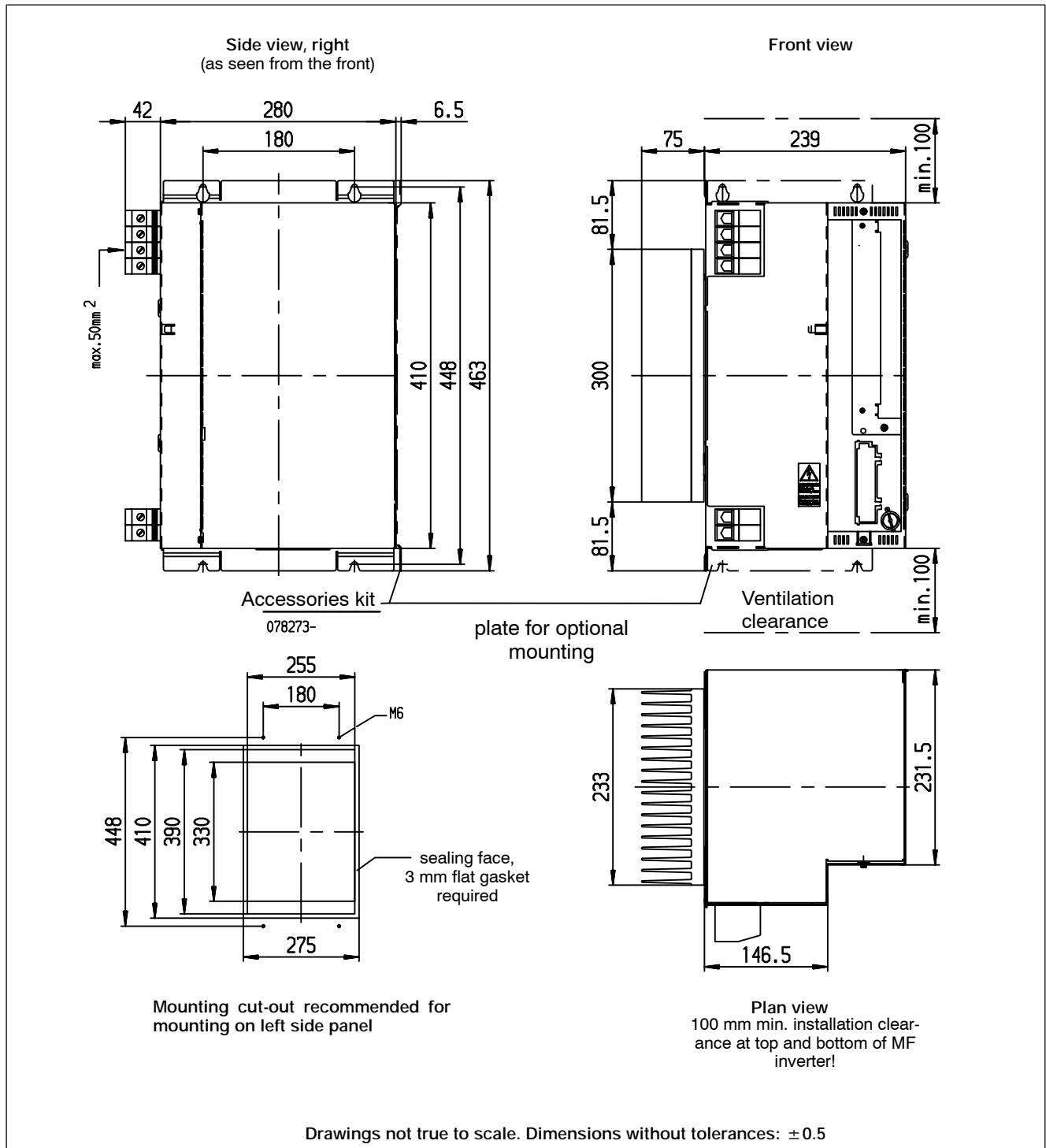

Dimensioned drawing, PSI 6100.XXX L1/L2

9.6 Dimensioned drawing, PSI 6100.XXX W1/W2

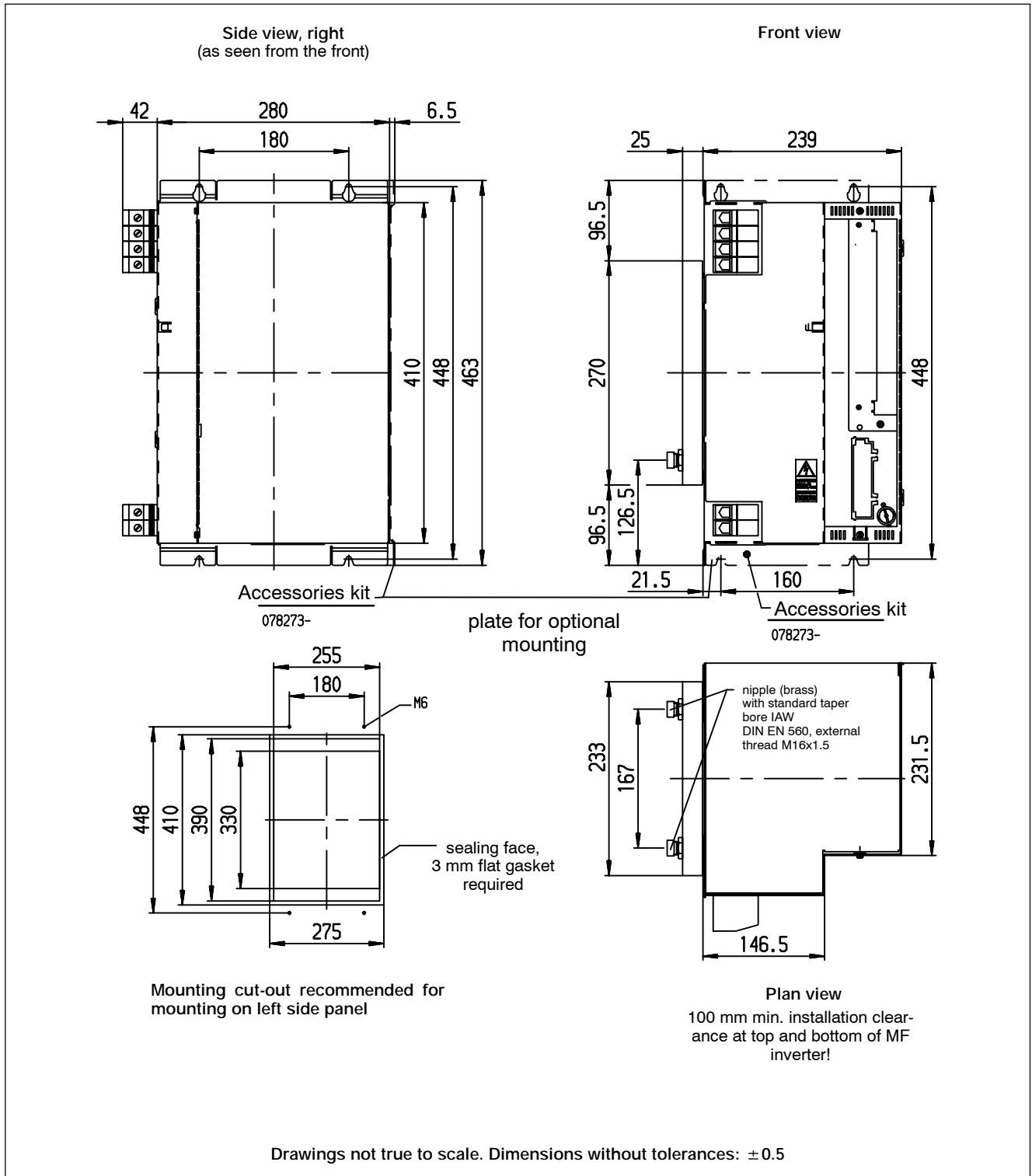

Dimensioned drawing, PSI 6100.XXX W1/W2

## 9.7 Electrical connection, PSI 6100.XXX L1/L2/W1/W2

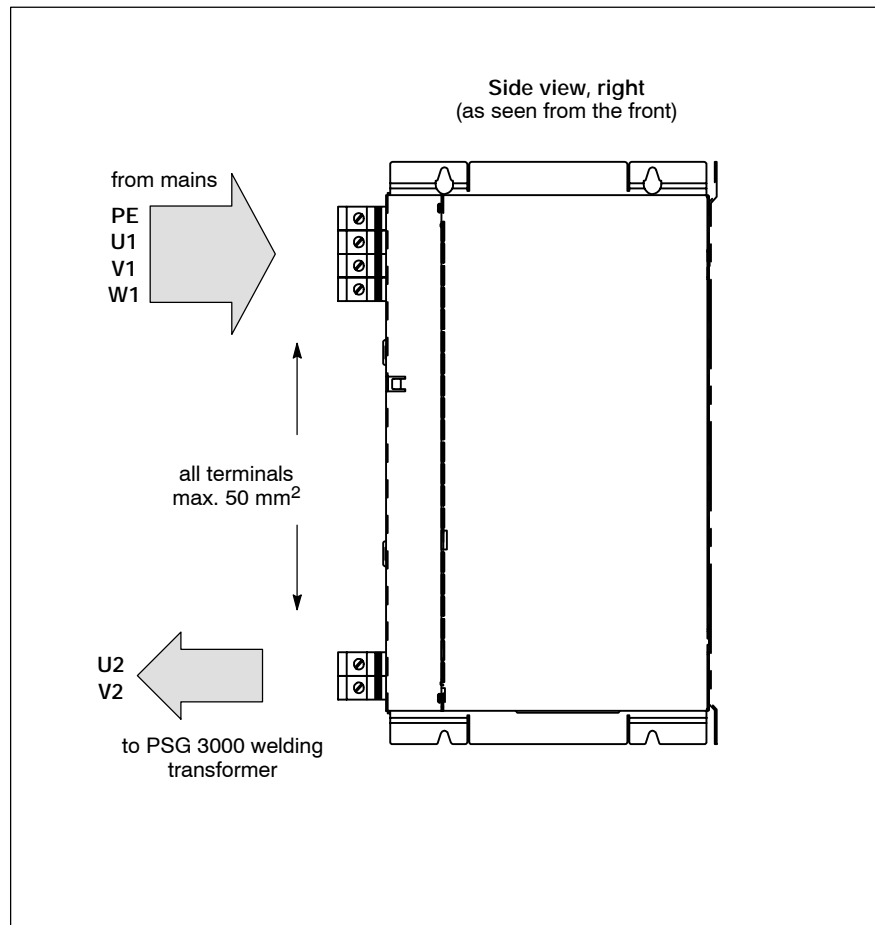

Electrical connection, PSI 6100.XXX L1/L2/W1/W2

Note: For the connections of the various control functions, please see the respective manuals "PSI 6000, Control and I/O Level Description".

9.8 Cooling water connection, PSI 6100.XXX W1/W2

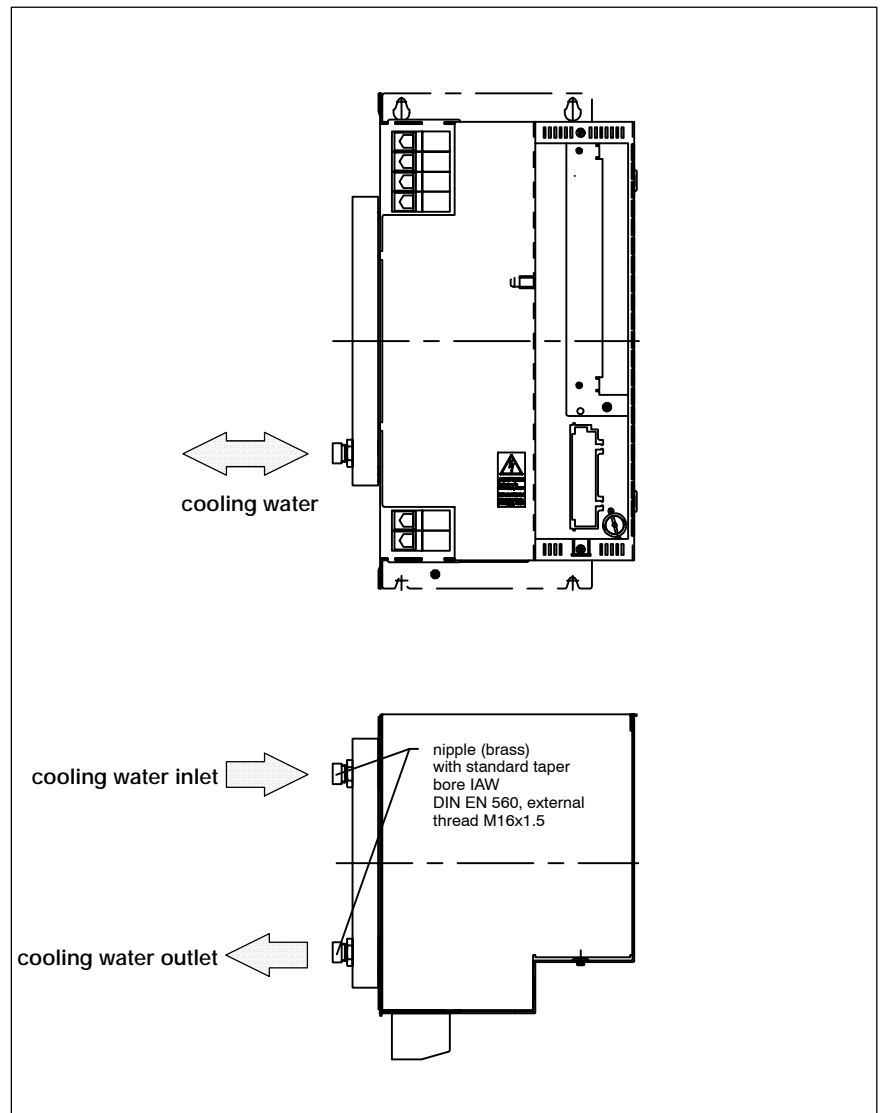

*Cooling water connection, PSI 6100.XXX W1/W2*

The heat sink of the water-cooled MF inverter is connected internally to the protective earth conductor.

Maximum water inlet temperature : 30° C  
Water connection : M 16 x 1.5  
external thread (DIN EN 560,  
nut: DIN 13-6)

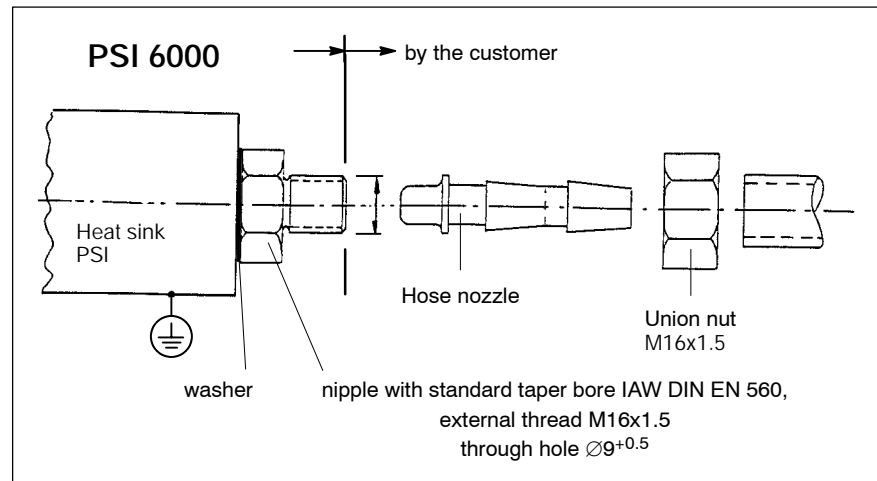

*Cooling water connection*

9.9 Load diagram, PSI 6100.XXX L1/W1

Note: For a general description of load diagrams, see Section 3.1

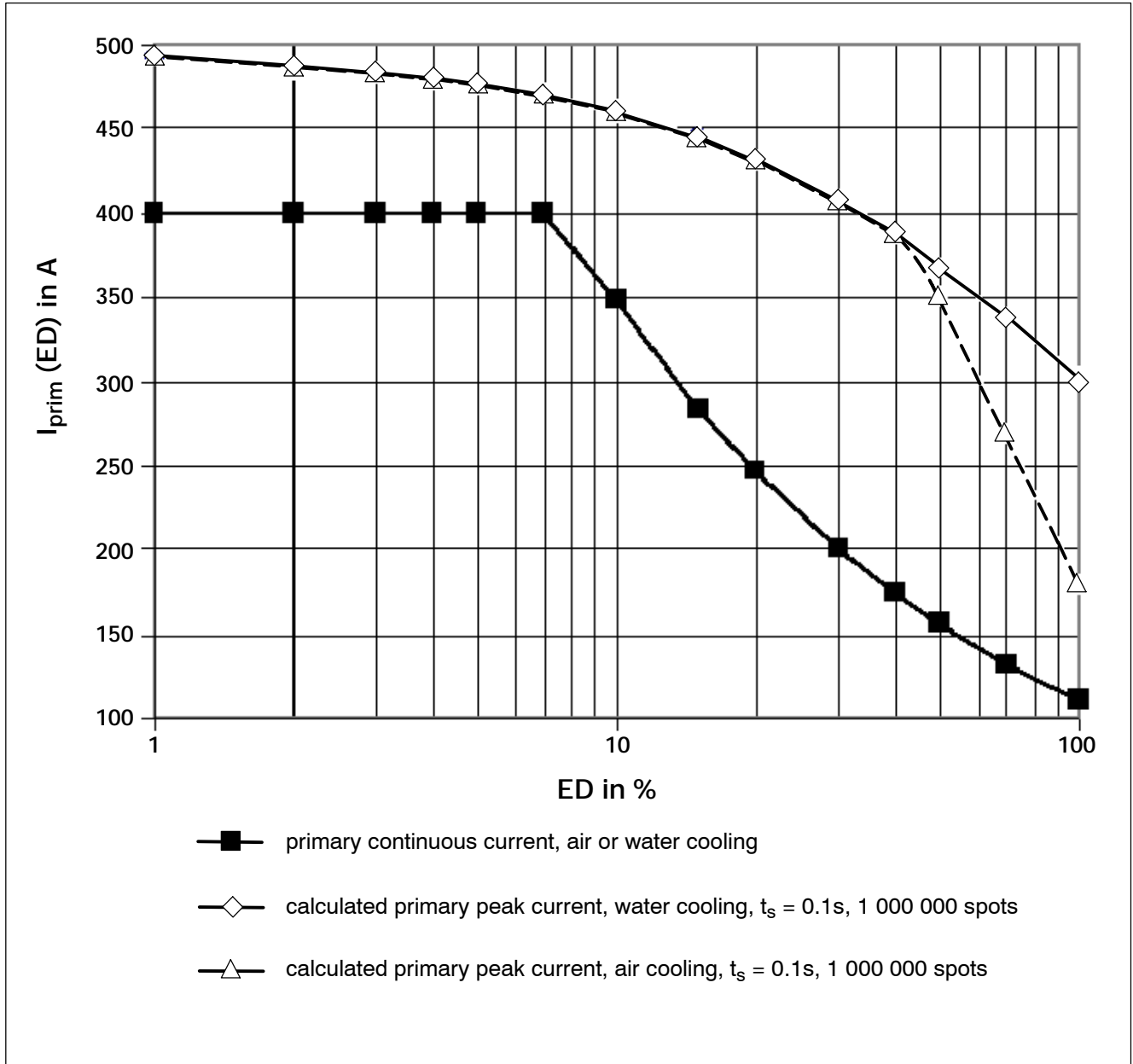

Load diagram, PSI 6100.XXX L1/W1

## 9.10 Load diagram, PSI 6100.XXX L2/W2

Note: For a general description of load diagrams, see Section 3.1

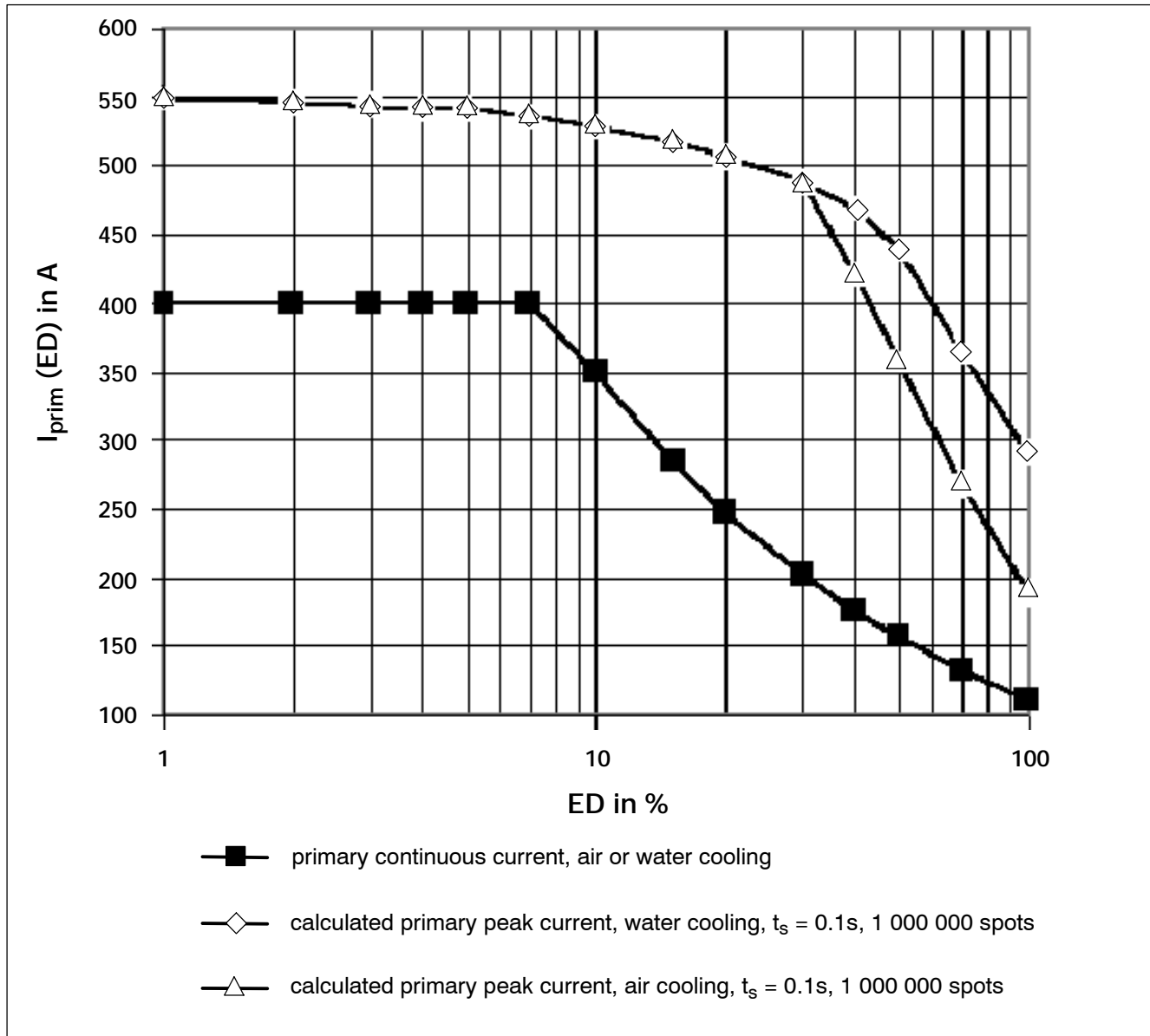

Load diagram, PSI 6100.XXX L2/W2

9.11 Accessories, PSI 6100.XXX L1/L2/W1/W2

9.11.1 Dimensioned drawing, accessories kit

An accessories kit is available for mounting the inverter with its back on the mounting plate.

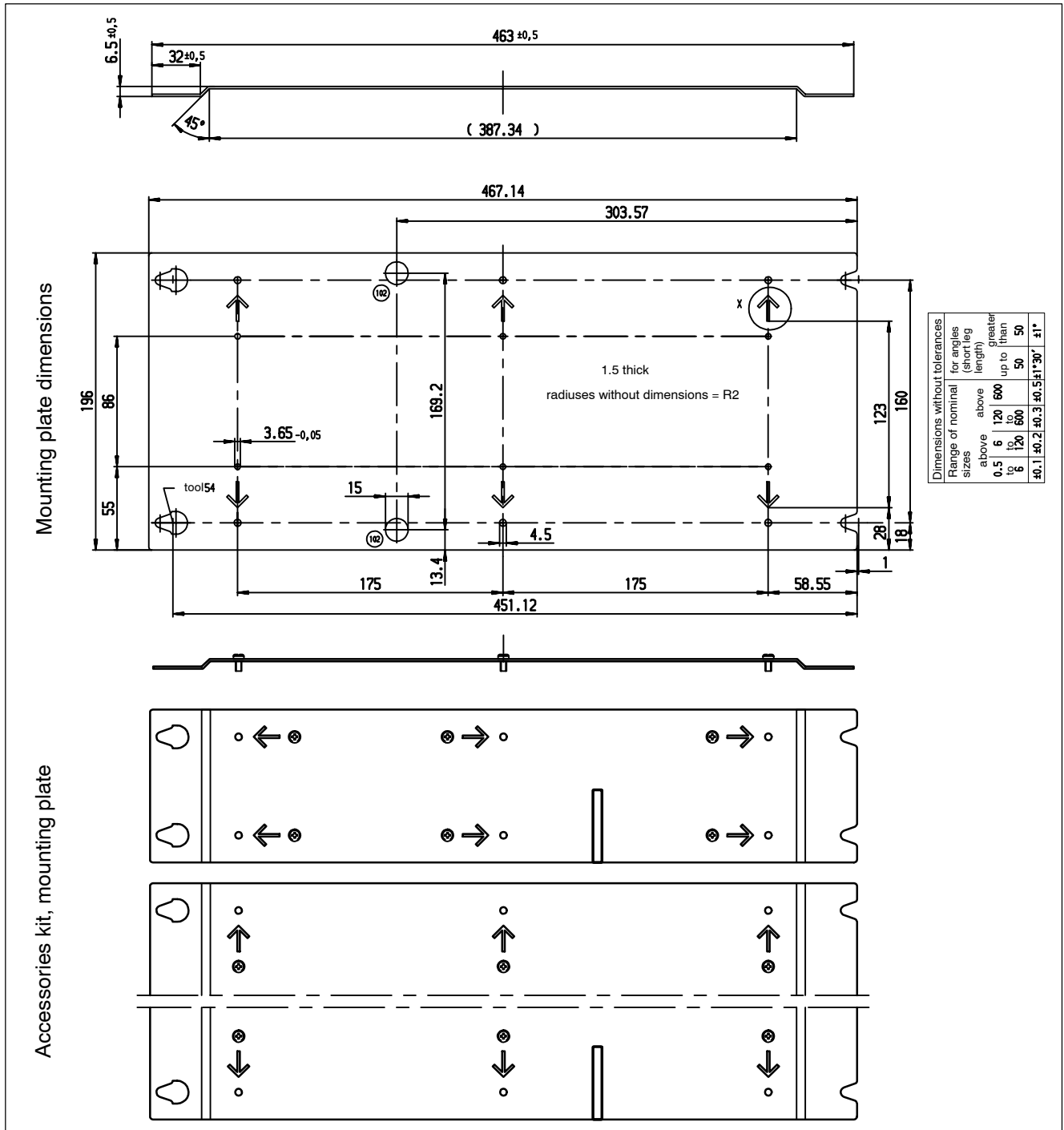

Dimensioned drawing, accessories kit

- D For PSG 3000 welding transformers, see Technical Information, PSG 3000 MF Welding Transformers, part no. 1070 080 087.
- D For I/O module, see Technical Information, PSI 6000, Control and I/O Level Description.
- D For insertable profiles for electric connection, see the section on ordering.

## 9.12 Ordering, PSI 6100.XXX L1/L2/W1/W2

Designation	Part no.
PSI 6100.100 L1 medium-frequency inverter	1070 079 211
PSI 6100.200 L1 medium-frequency inverter	1070 079 359
PSI 6101.321 L2 medium-frequency inverter	1070 079 286
PSI 6100.330 L2 medium-frequency inverter	on request
PSI 6100.100 W1 medium-frequency inverter	1070 079 210
PSI 6100.100 W2 medium-frequency inverter	on request

Not included in shipment:

Designation	Part no.
Insertable profile for pin connectors on small wire sizes, line connection and welding transformer connection	1070 918 779
Accessories kit for PSI 6100.XXX L1/L2/W1/W2 mounting	1070 078 273
SSR 81.00 current sensor without fixing device, in the form of a toroid coil; 55 mm internal diameter; with 5-pole sleeve terminal	1070 048 099
SSR 81.01-08 current sensor with fixing device; e.g. for various electrode makes	on request
Mating connector for SSR 81.0X current sensor	1070 913 489
Sensor cable LiYCY 2x2x0,75 mm <sup>2</sup> shielded	1070 913 494

Notes:

## 10 PSI 6200.XXX W1/W2

### 10.1 PSI 6200.XXX W1/W2 overview

- D PSI 6200.XXX W1:
  - D water-cooled
  - D 400 V -20% to 480 V +10%, 50/60 Hz
- D PSI 6200.XXX W2:
  - D water-cooled
  - D 480 V -20% to 690 V +10%, 50/60 Hz

### 10.2 Explanation of drawings

The following drawings show the

- D front plate with modules of the MF inverter
  - D integrated weld timer
  - D slot for the parallel, serial or fieldbus I/O interface
  - D slot prepared for retrofitting a quality module
  - D slot for fieldbus interface for programming (optional)
- D technical data
- D dimensions and mounting options
- D mains connection
  - D connection of the PSG 3000 welding transformer
- D load diagram
- D accessories and part numbers

. **Note:** No water connections shown on drawings.

## 10.3 PSI 6200.XXX W1/W2 front panel

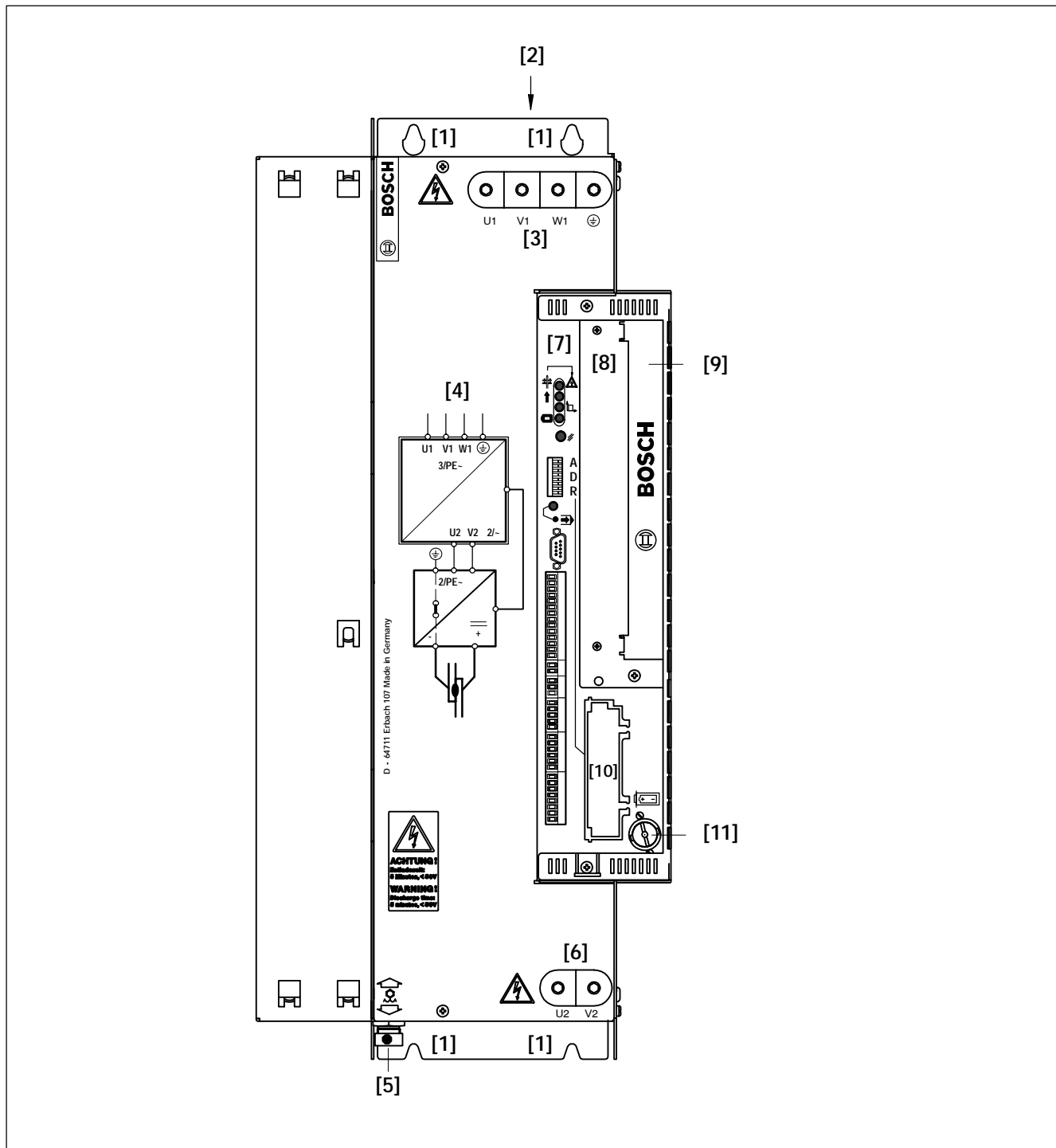

PSI 6200.XXX W1/W2 front panel

- [1] M6 mounting options  
D rear panel
- [2] fan
- [3] mains supply connection
- [4] MF inverter symbol

- [5] Cooling water connection  
nipple (brass) with standard taper bore IAW DIN EN 560,  
external thread M16x1.5
- [6] PSG 3000 welding transformer connection
- [7] integrated weld timer
- [8] slot for type-specific I/O interface:
  - D parallel I/O interface
  - D serial I/O interface
  - D fieldbus I/O interface
- [9] slot for retrofitting a quality module
- [10] slot for fieldbus interface for programming
- [11] battery compartment

## 10.4 Technical data, PSI 6200.XXX W1/W2

Type	3-phase MF inverter, module designed for recessed mounting
Weld timer	integrated
I/O interface	Slot for parallel, serial or fieldbus interface
Quality module	Slot prepared for retrofitting
Degree of protection	IP 20; designed for modular enclosure or for installation in switchgear cabinets with IP 54
Inverter ambient temperature	max. 55° C
Cooling	W1/W2: water 4 l/min.; max. 30° C
Temperature monitoring	integrated
Storage temperature	-25° C to +70° C
Corrosion	The ambient air must be free of acids, caustic solutions, corrosive agents, salts and metal vapors of any major concentration
Humidity	Humidity class F as per DIN 40040; 20° C at 90% relative humidity; 40° C at 50% relative humidity (as per VDE 0113); Moisture condensation on the MF inverters must be prevented.
Air pressure	Any within a range of up to 2000 m above sea level
Line voltage connection grounded TN or TT system	W1: 400 V -20% to 480 V +10%; 50/60 Hz W2: 480 V -20% to 690 V +10%; 50/60 Hz
Nominal system current; max. continuous thermal current	220 A
Max. output current	1200 A
Max. secondary current; depending on the transformer used	54 kA (PSG 3100)
Voltage supply; Weld timer CPU; I/O interface	24 V DC; min. 19 V DC up to max. 30 V DC as per EN 61131-2, (external power supply), or, alternatively, power supply from the weld current system (internal power supply)
Clock frequency	1 kHz
Overvoltage protection	MOV; Metal Oxide Varistor
Electrical connection, mains supply and transformer	high-current bushing terminal; max. 95 mm <sup>2</sup>
Wire range	95 mm <sup>2</sup>
Basic switchgear cabinet loss	W1: 69 W W2: 100 W
Max. ventilating and cooling loss dissipated via external air-cooler	W1: 700 W W2: 800 W
Switchgear cabinet loss at max. power	W1: 210 W W2: 240 W
Weight	W1/W2: approx. 56 kg
Mounting position	vertical or with its back on mounting plate

10.5 Dimensioned drawing, PSI 6200.XXX W1/W2

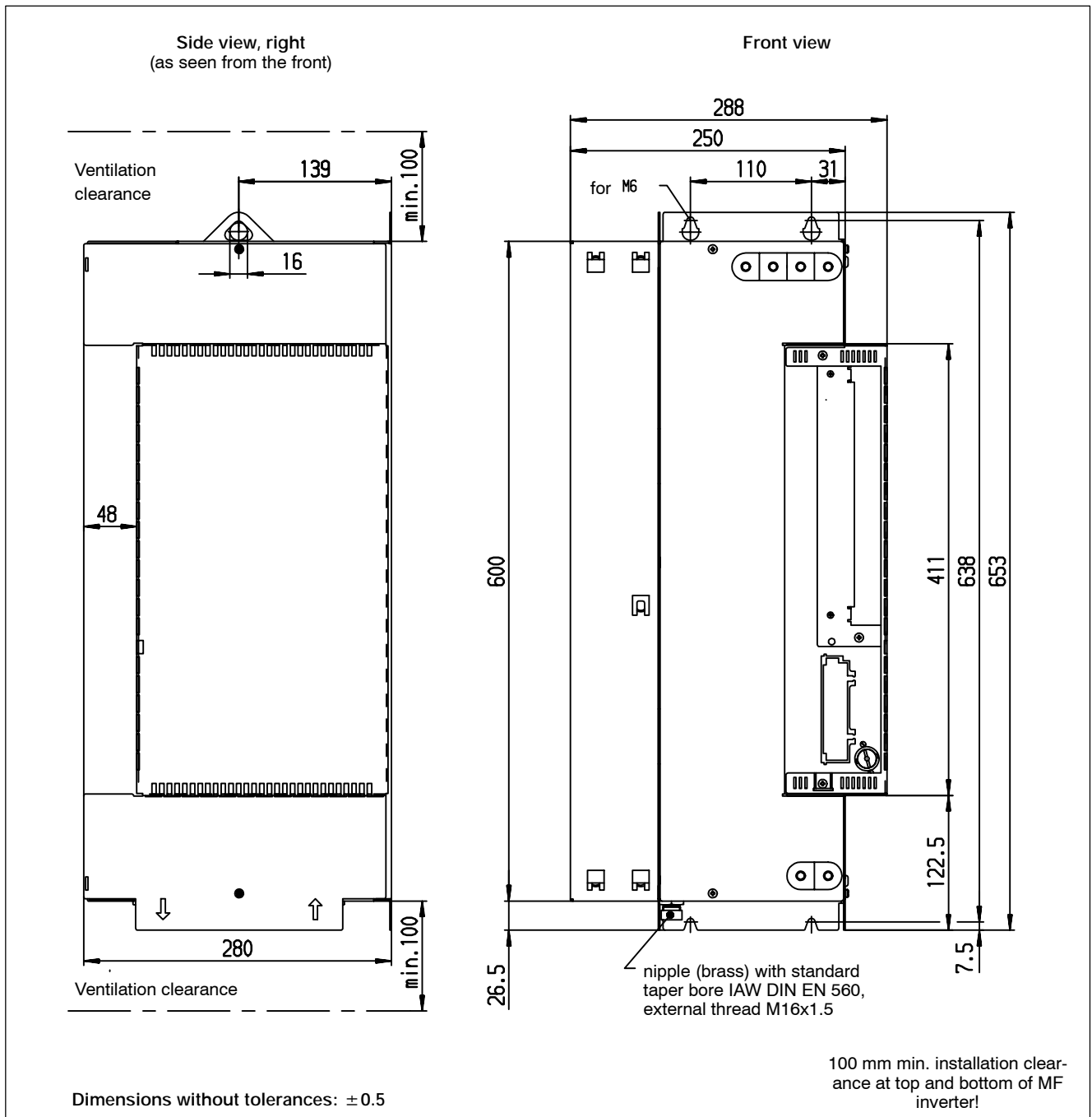

Dimensioned drawing, PSI 6200.XXX W1/W2

## 10.6 Electrical connection, PSI 6200.XXX W1/W2

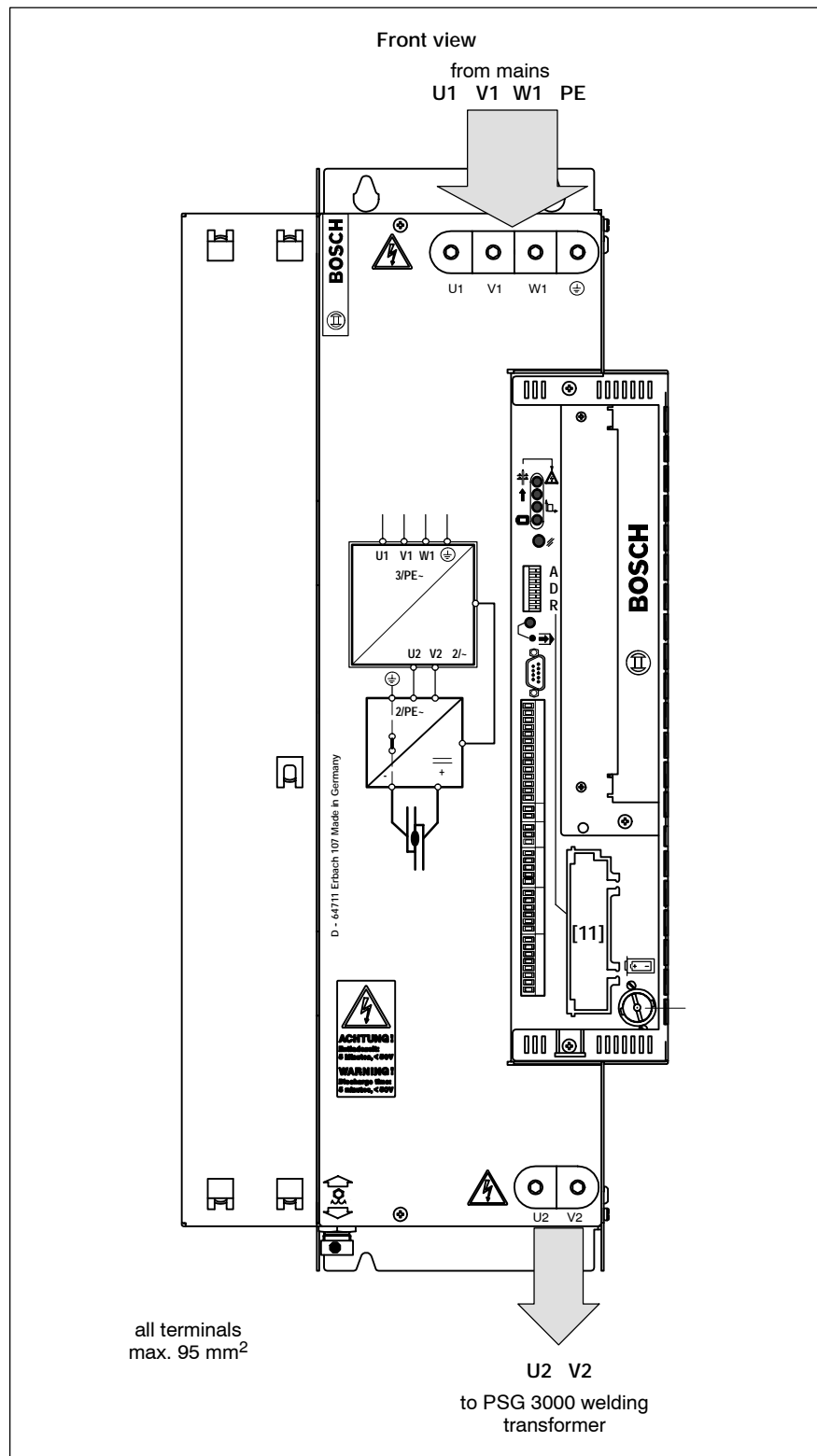

Electrical connection, PSI 6200.XXX W1/W2

Note: For the connections of the various control functions, please see the respective manuals "PSI 6000, Control and I/O Level Description".

10.7 Cooling water connection, PSI 6200.XXX W1/W2

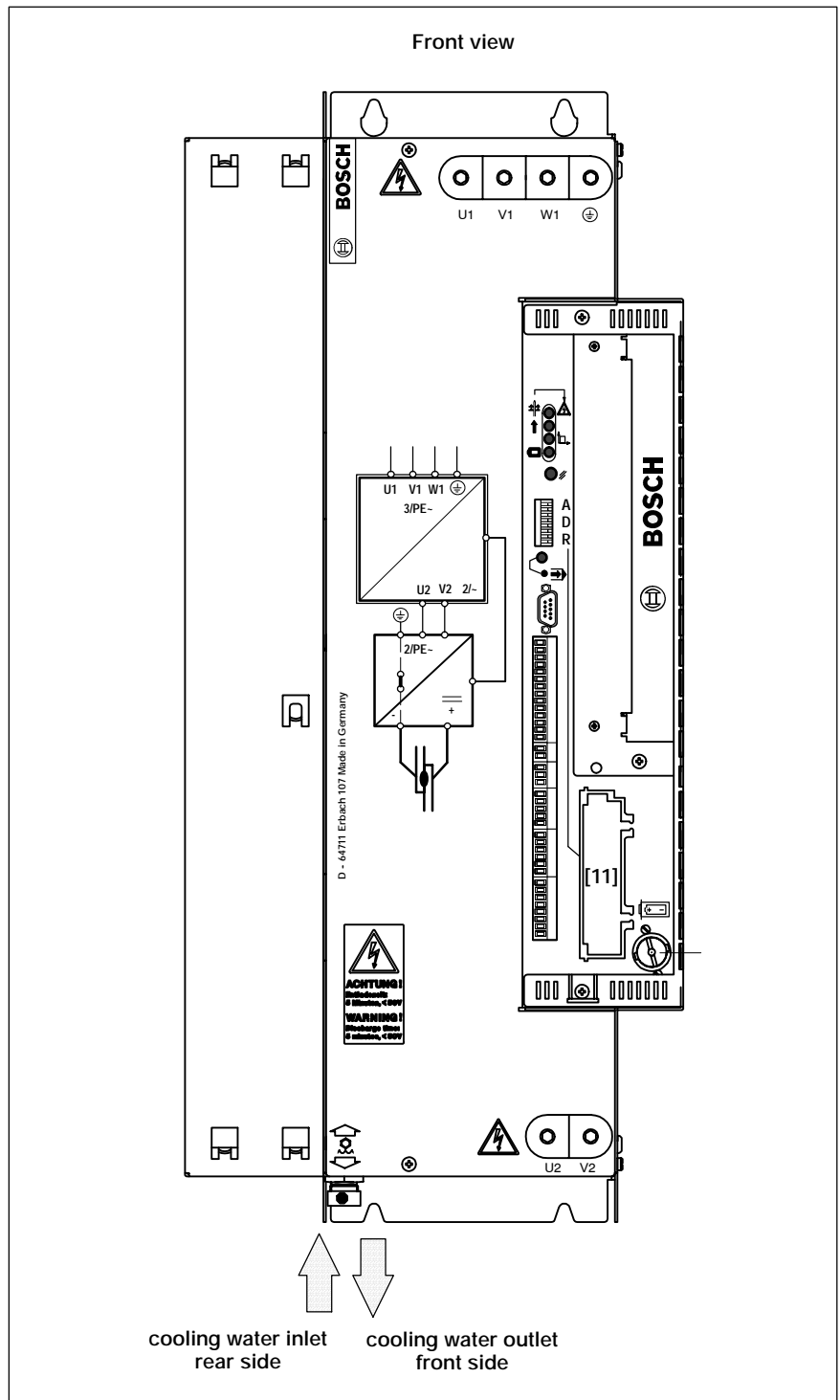

Cooling water connection, PSI 6200.XXX W1/W2

The heat sink of the water-cooled MF inverter is connected internally to the protective earth conductor.

Maximum water inlet temperature : 30° C  
Water connection : M 16 x 1.5  
external thread (DIN EN 560,  
nut: DIN 13-6)

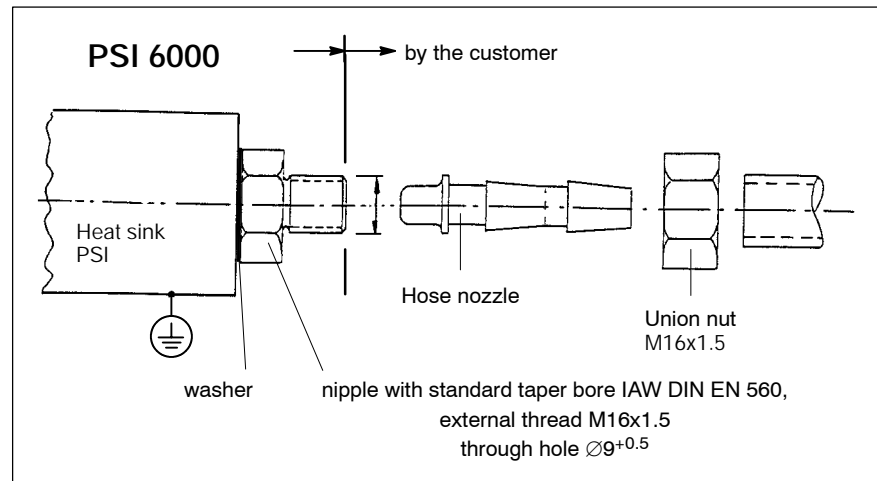

*Cooling water connection*

10.8 Load diagram, PSI 6200.XXX W1

Note: For a general description of load diagrams, see Section 3.1

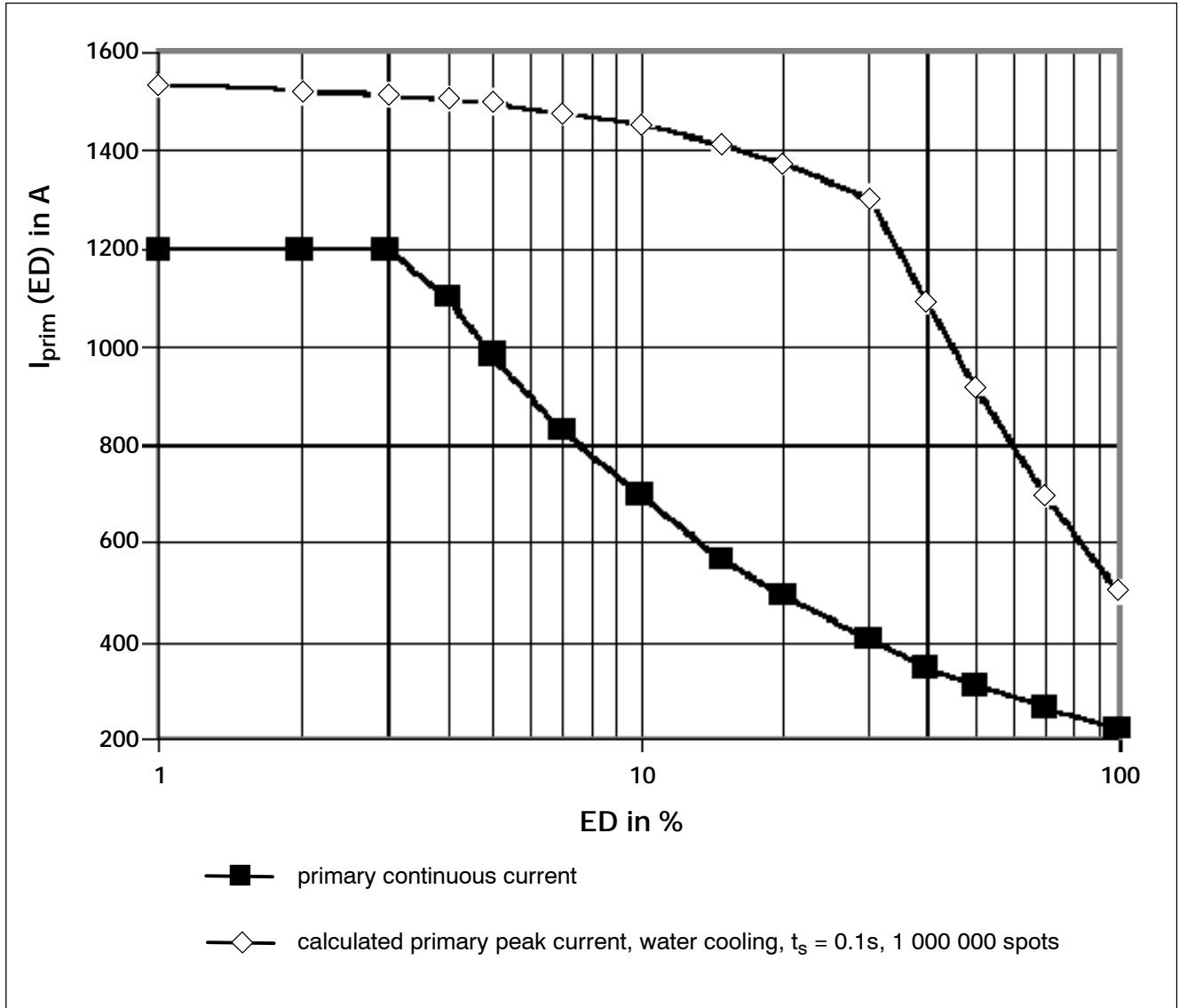

Load diagram, PSI 6200.XXX W1

## 10.9 Load diagram, PSI 6200.XXX W2

Note: For a general description of load diagrams, see Section 3.1

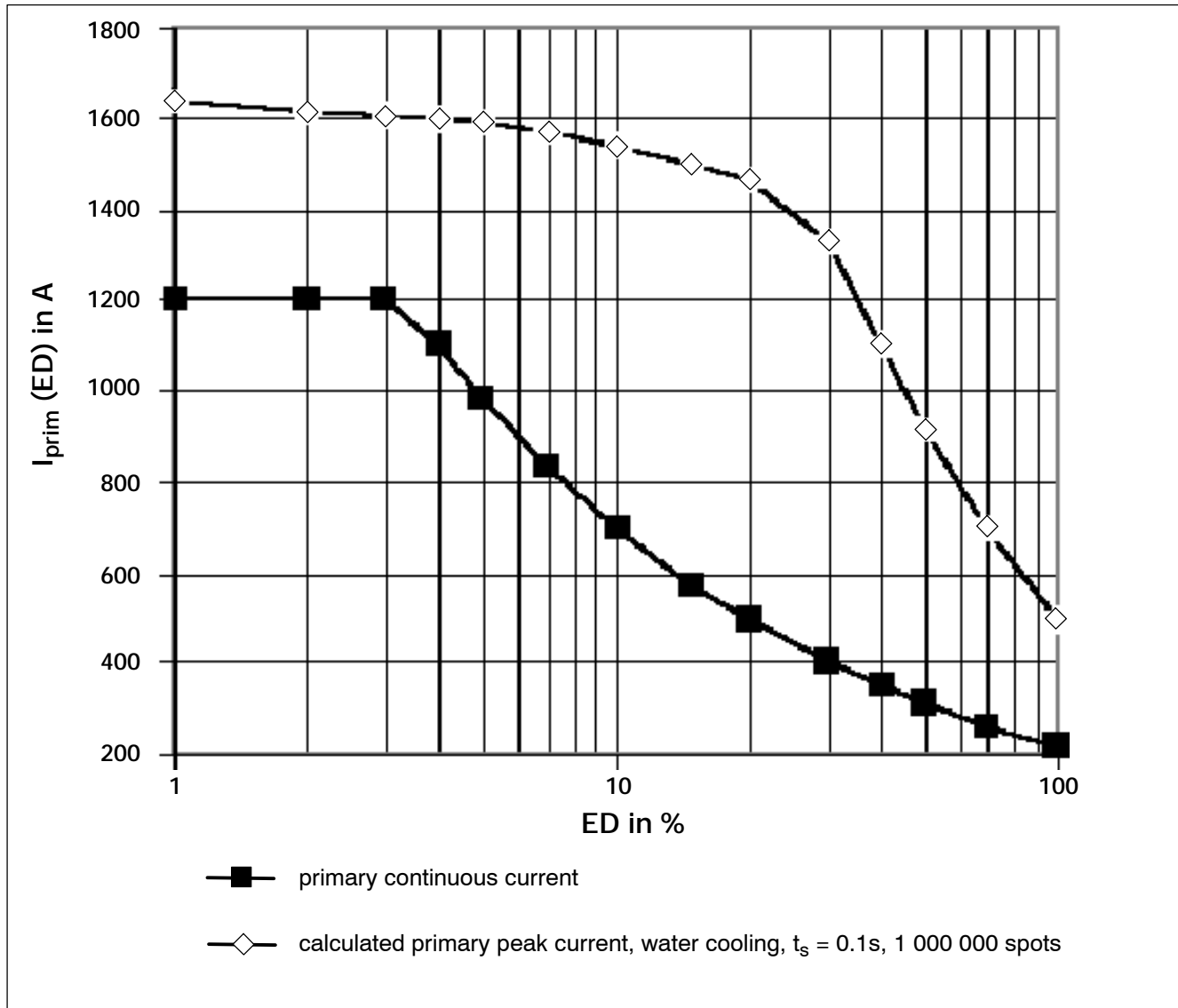

Load diagram, PSI 6200.XXX W2

## 10.10 Accessories, PSI 6200.XXX W1/W2

- D For PSG 3000 welding transformers, see Technical Information, PSG 3000 MF Welding Transformers, part no. 1070 080 087.
- D For I/O module, see Technical Information, PSI 6000, Control and I/O Level Description.

## 10.11 Ordering, PSI 6200.XXX W1/W2

Designation	Part no.
PSI 6200.100 W1 medium-frequency inverter	1070 081 748
PSI 6200.321 W1 medium-frequency inverter	1070 081 749
PSI 6200.100 W2 medium-frequency inverter	on request

Not included in shipment:

Designation	Part no.
SSR 81.00 current sensor without fixing device, in the form of a toroid coil; 55 mm internal diameter; with 5-pole sleeve terminal	1070 048 099
SSR 81.01-08 current sensor with fixing device; e.g. for various electrode makes	on request
Mating connector for SSR 81.0X current sensor	1070 913 489
Sensor cable LiYCY 2x2x0,75 mm <sup>2</sup> shielded	1070 913 494

# 11 PSI 6300.XXX L1/L2/W1/W2

## 11.1 PSI 6300.XXX L1/L2/W1/W2 overview

- D PSI 6300.XXX L1:
  - D air-cooled
  - D 400 V -20% to 480 V +10%, 50/60 Hz
  
- D PSI 6300.XXX L2:
  - D air-cooled
  - D 480 V -20% to 690 V +10%, 50/60 Hz
  
- D PSI 6300.XXX W1:
  - D water-cooled
  - D 400 V -20% to 480 V +10%, 50/60 Hz
  
- D PSI 6300.XXX W2:
  - D water-cooled
  - D 480 V -20% to 690 V +10%, 50/60 Hz

## 11.2 Explanation of drawings

The following drawings show the

- D front plate with modules of the MF inverter
  - D integrated weld timer
  - D slot for the parallel, serial or fieldbus I/O interface
  - D slot prepared for retrofitting a quality module
  - D slot for fieldbus interface for programming (optional)
  
- D technical data
- D dimensions and mounting options
- D mains connection
  - D connection of the PSG 3000 welding transformer
  
- D load diagram
- D accessories and part numbers

. **Note: No heat sinks or water connections shown on drawings.**

## 11.3 PSI 6300.XXX L1/L2/W1/W2 front panel

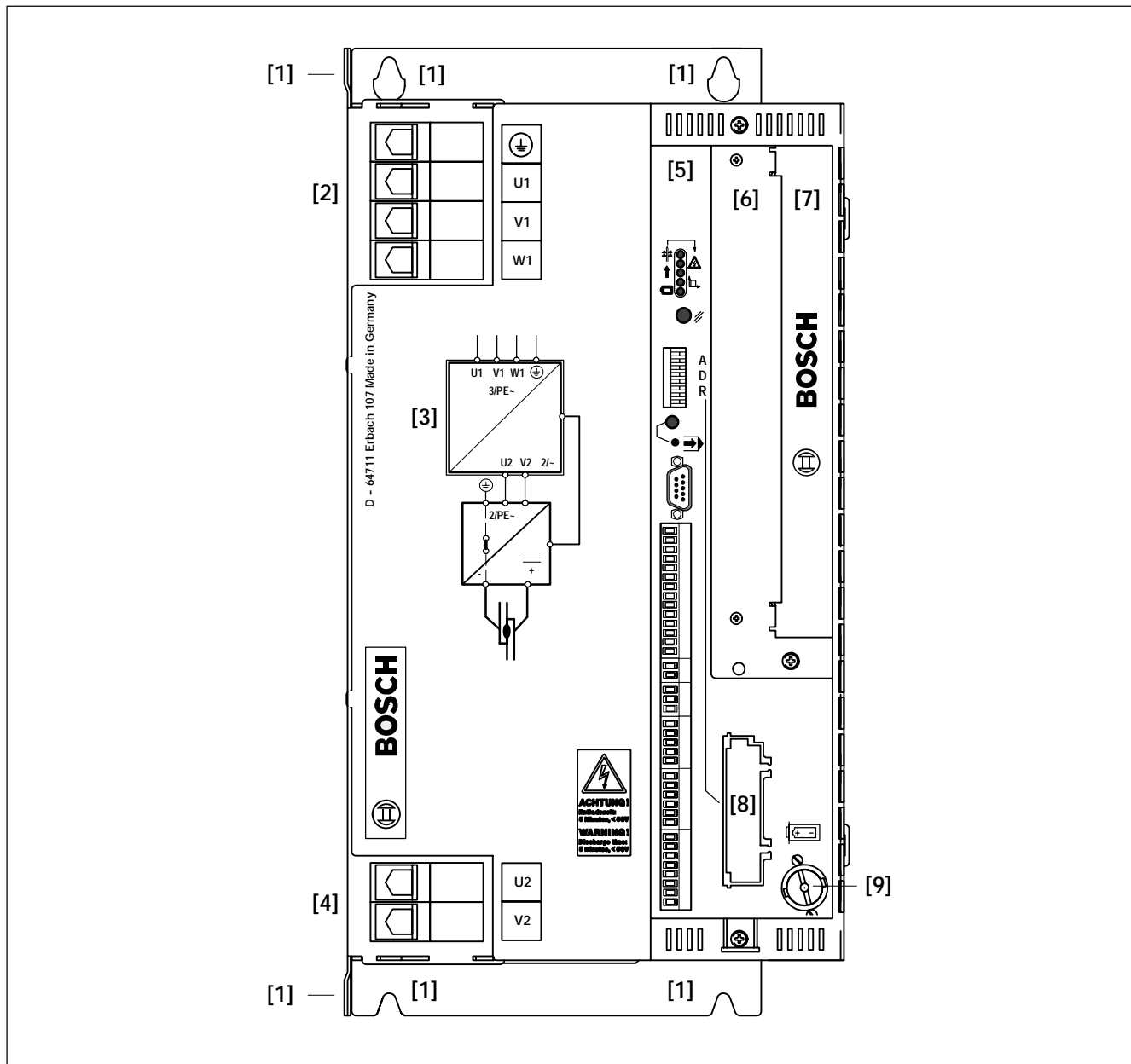

PSI 6300.XXX L1/L2/W1/W2 front panel

- [1] M6 mounting options
  - D rear panel
  - D left side panel (mounting cutout required)
- [2] mains supply connection
- [3] MF inverter symbol
- [4] PSG 3000 welding transformer connection
- [5] integrated weld timer
- [6] slot for type-specific I/O interface:
  - D parallel I/O interface
  - D serial I/O interface
  - D fieldbus I/O interface

- [7] slot for retrofitting a quality module
- [8] slot for fieldbus interface for programming
- [9] battery compartment

## 11.4 Technical data, PSI 6300.XXX L1/L2/W1/W2

Type	3-phase MF inverter, module designed for recessed mounting
Weld timer	integrated
I/O interface	Slot for parallel, serial or fieldbus interface
Quality module	Slot prepared for retrofitting
Degree of protection	IP 20; designed for modular enclosure or for installation in switchgear cabinets with IP 54
Inverter ambient temperature	max. 55° C
Cooling	L1/L2: air, max. 45° C with Bosch fan cowl, temperature-controlled through inverter W1/W2: water, 4 l/min; max. 30° C
Temperature monitoring	integrated
Storage temperature	-25° C to +70° C
Corrosion	The ambient air must be free of acids, caustic solutions, corrosive agents, salts and metal vapors of any major concentration
Humidity	Humidity class F as per DIN 40040; 20° C at 90% relative humidity; 40° C at 50% relative humidity (as per VDE 0113); Moisture condensation on the MF inverters must be prevented.
Air pressure	Any within a range of up to 2000 m above sea level
Line voltage connection grounded TN or TT system	L1/W1: 400 V -20% to 480 V +10%; 50/60 Hz L2/W2: 480 V -20% to 690 V +10%; 50/60 Hz
Nominal system current; max. continuous thermal current	110 A
Max. output current	800 A
Max. secondary current; depending on the transformer used	36 kA (PSG 3100)
Voltage supply; Weld timer CPU; I/O interface	24 V DC; min. 19 V DC up to max. 30 V DC as per EN 61131-2, (external power supply), or, alternatively, power supply from the weld current system (internal power supply)
Clock frequency	1 kHz
Overvoltage protection	MOV; Metal Oxide Varistor
Electrical connection, mains supply and transformer	via box terminal; max. 50 mm <sup>2</sup>
Wire range	35 mm <sup>2</sup>
Basic switchgear cabinet loss	L1/W1: 69 W L2/W2: 100 W

Max. ventilating and cooling loss dissipated via external air-cooler	L1/L2: 360 W W1: 420 W W2: 500 W
Switchgear cabinet loss at max. power	L1: 170 W L2: 200 W W1: 110 W W2: 140 W
Weight	L1: approx. 20 kg L2: approx. 21 kg W1: approx. 25 kg W2: approx. 26 kg
Mounting position	vertical or with its back on mounting plate

11.5 Dimensioned drawing, PSI 6300.XXX L1/L2

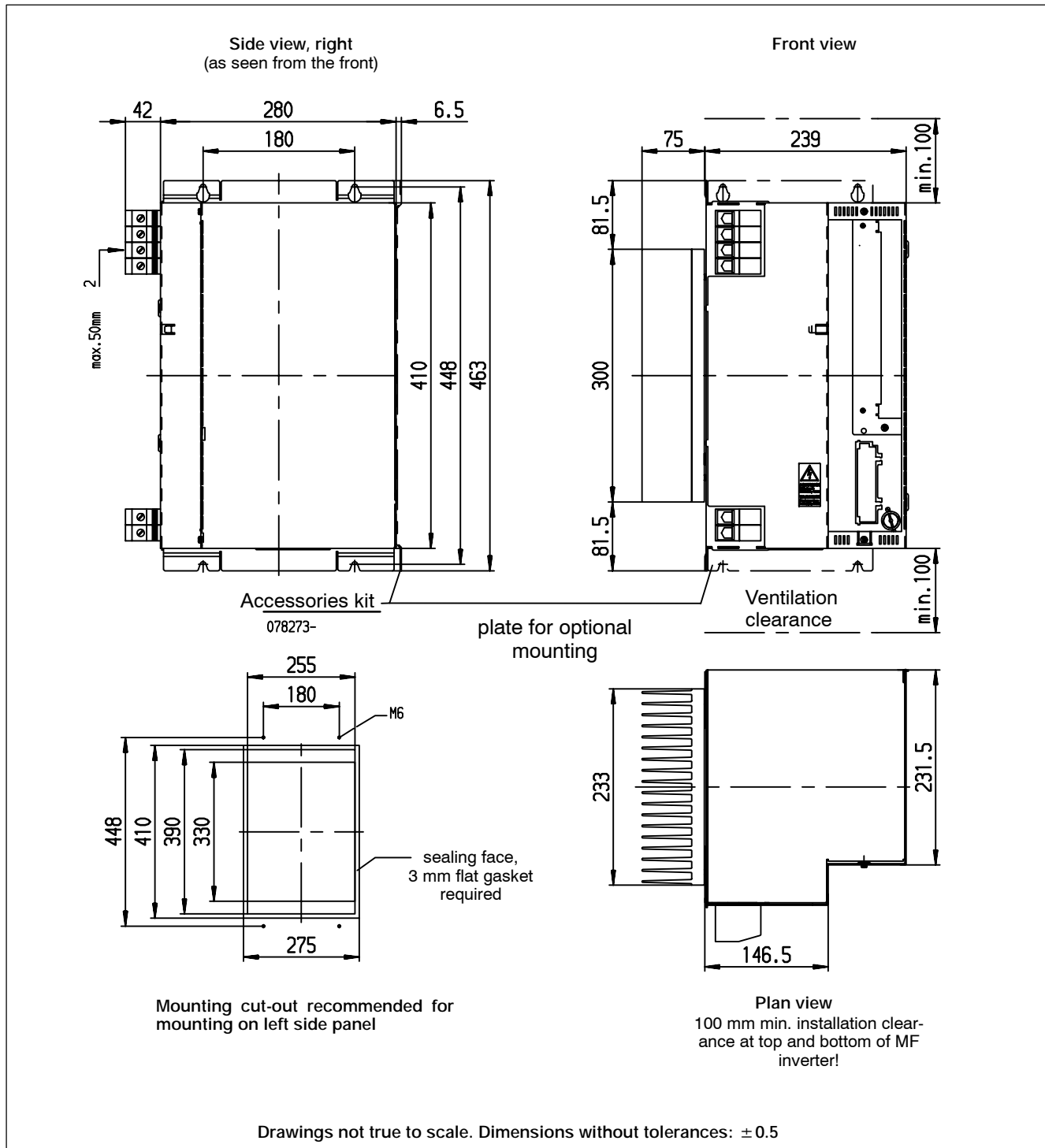

Dimensioned drawing, PSI 6300.XXX L1/L2

11.6 Dimensioned drawing, PSI 6300.XXX W1/W2

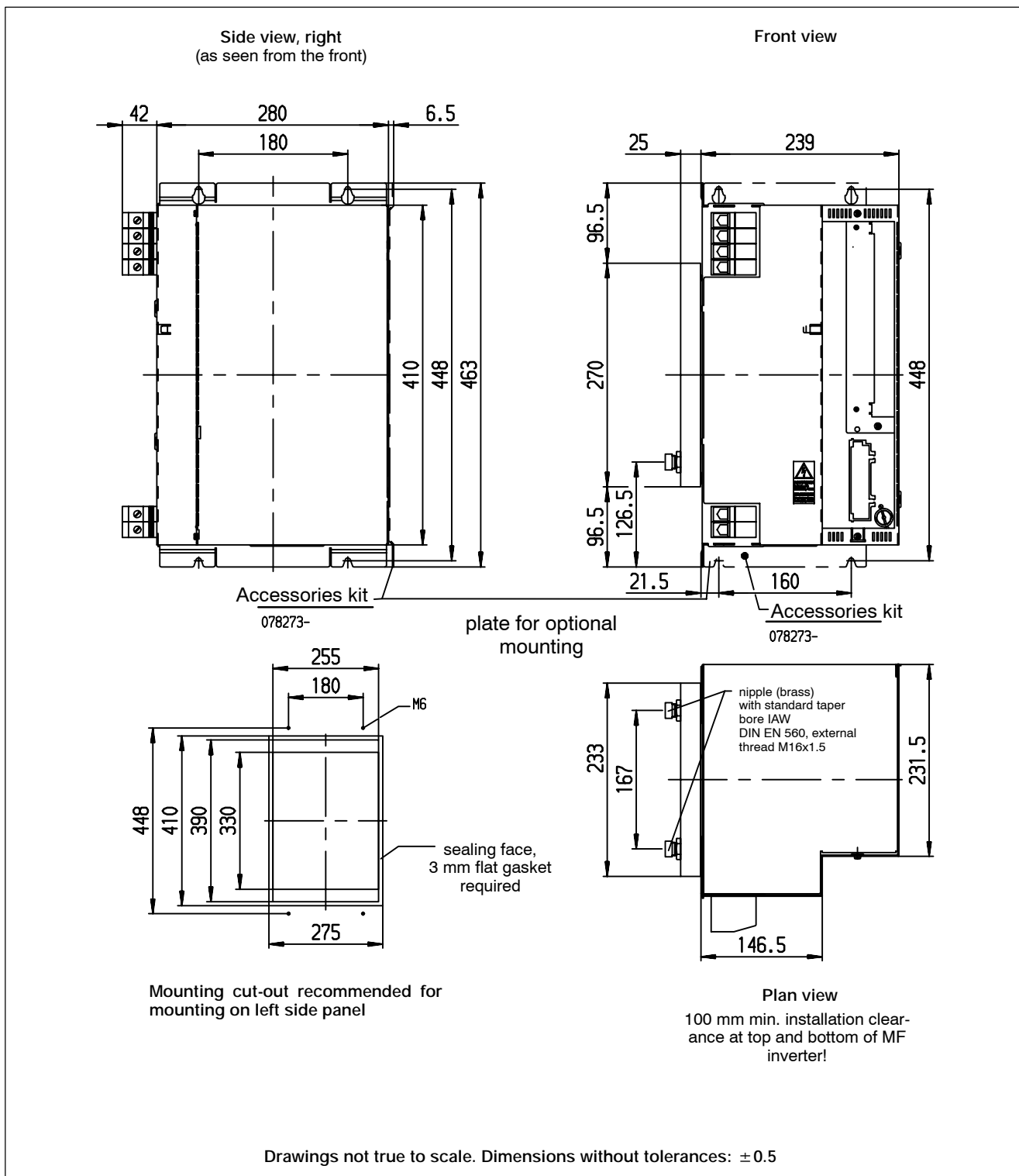

Dimensioned drawing, PSI 6300.XXX W1/W2

## 11.7 Electrical connection, PSI 6300.XXX L1/L2/W1/W2

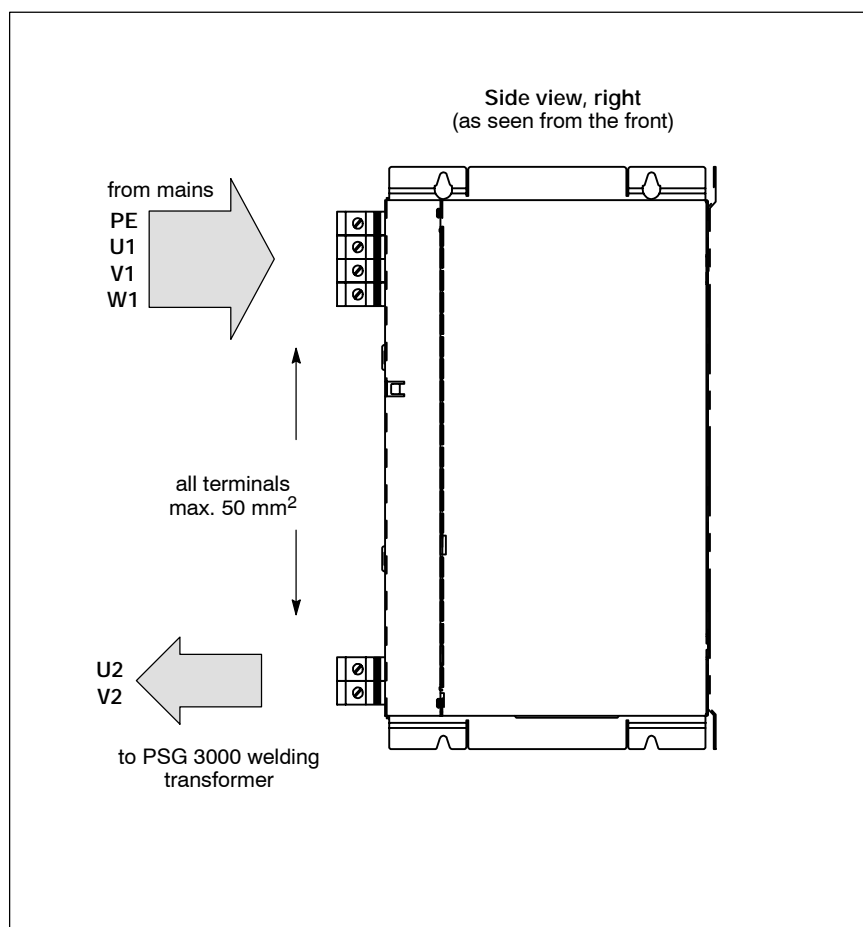

*Electrical connection, PSI 6300.XXX L1/L2/W1/W2*

**Note:** For the connections of the various control functions, please see the respective manuals "PSI 6000, Control and I/O Level Description".

11.8 Cooling water connection, PSI 6300.XXX W1/W2

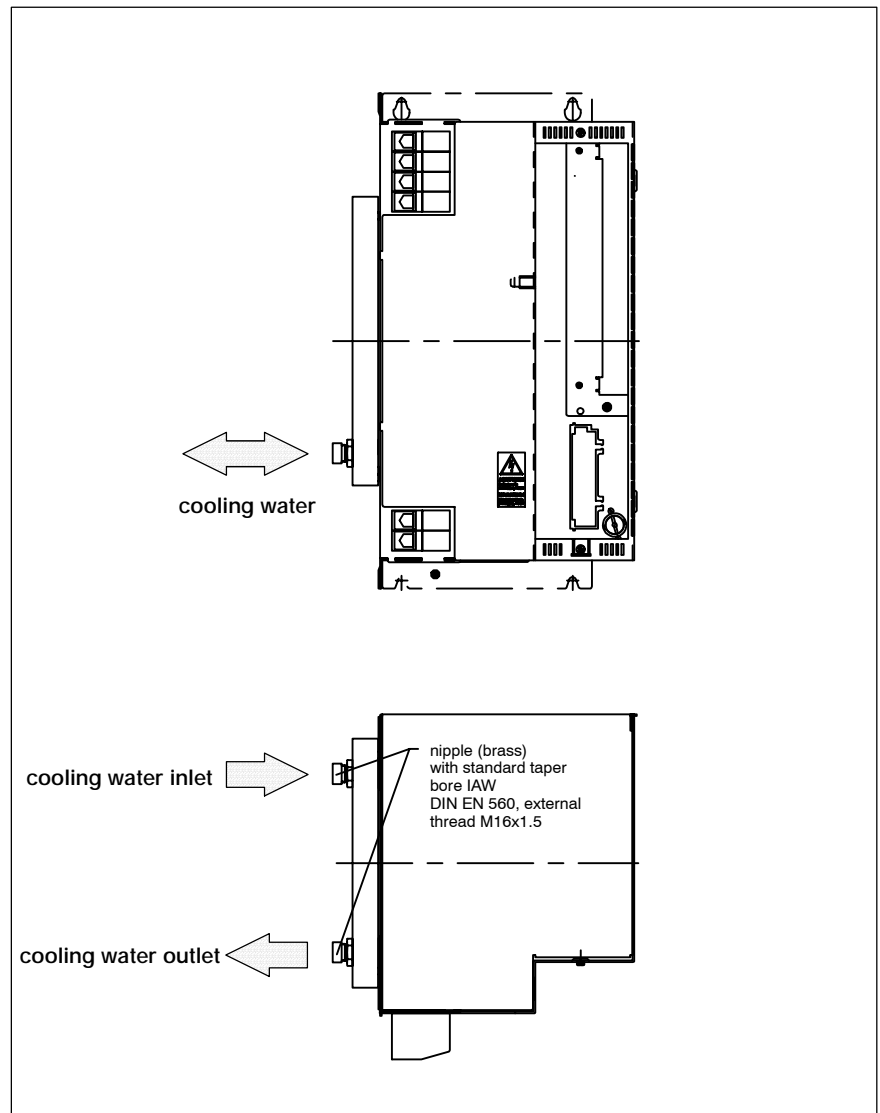

*Cooling water connection, PSI 6300.XXX W1/W2*

The heat sink of the water-cooled MF inverter is connected internally to the protective earth conductor.

Maximum water inlet temperature : 30° C  
Water connection : M 16 x 1.5  
external thread (DIN EN 560,  
nut: DIN 13-6)

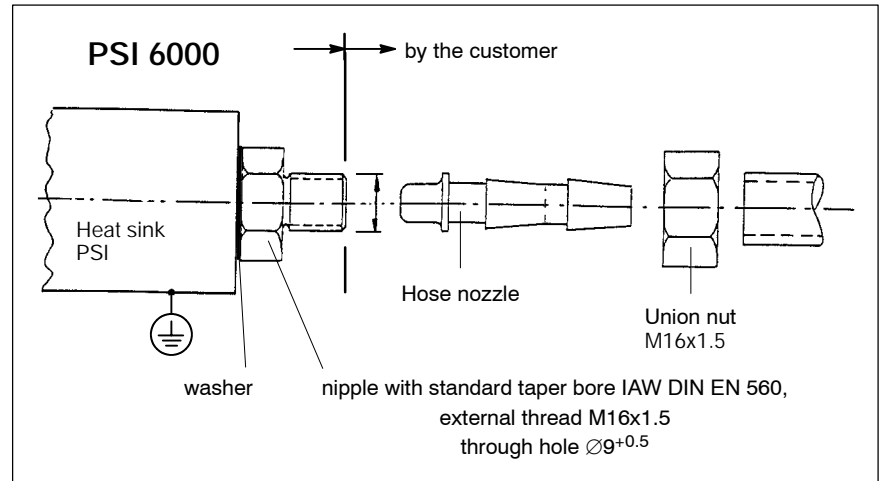

*Cooling water connection*

11.9 Load diagram, PSI 6300.XXX L1/W1

Note: For a general description of load diagrams, see Section 3.1

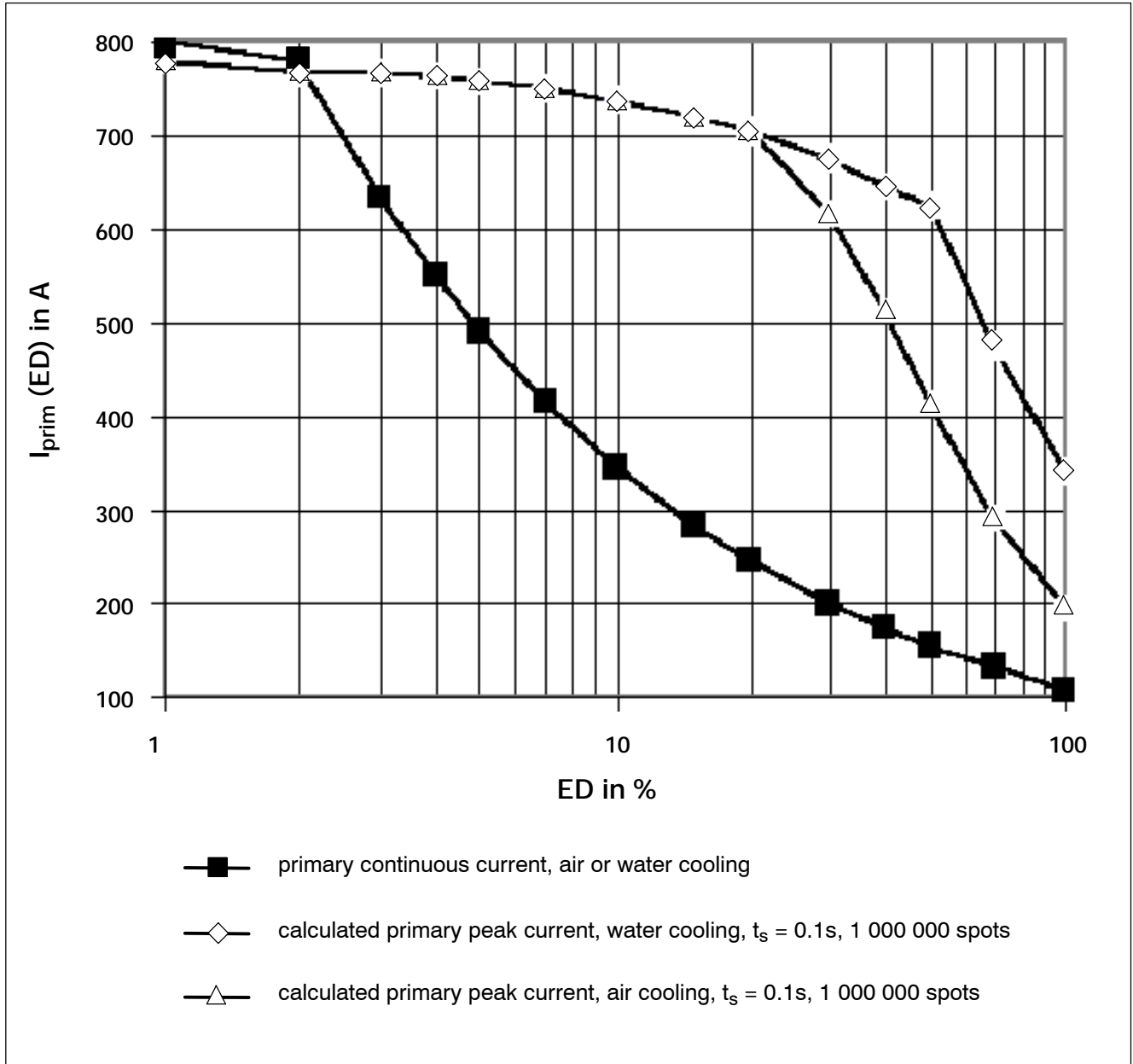

Load diagram, PSI 6300.XXX L1/W1

11.10 Load diagram, PSI 6300.XXX L2/W2

Note: For a general description of load diagrams, see Section 3.1

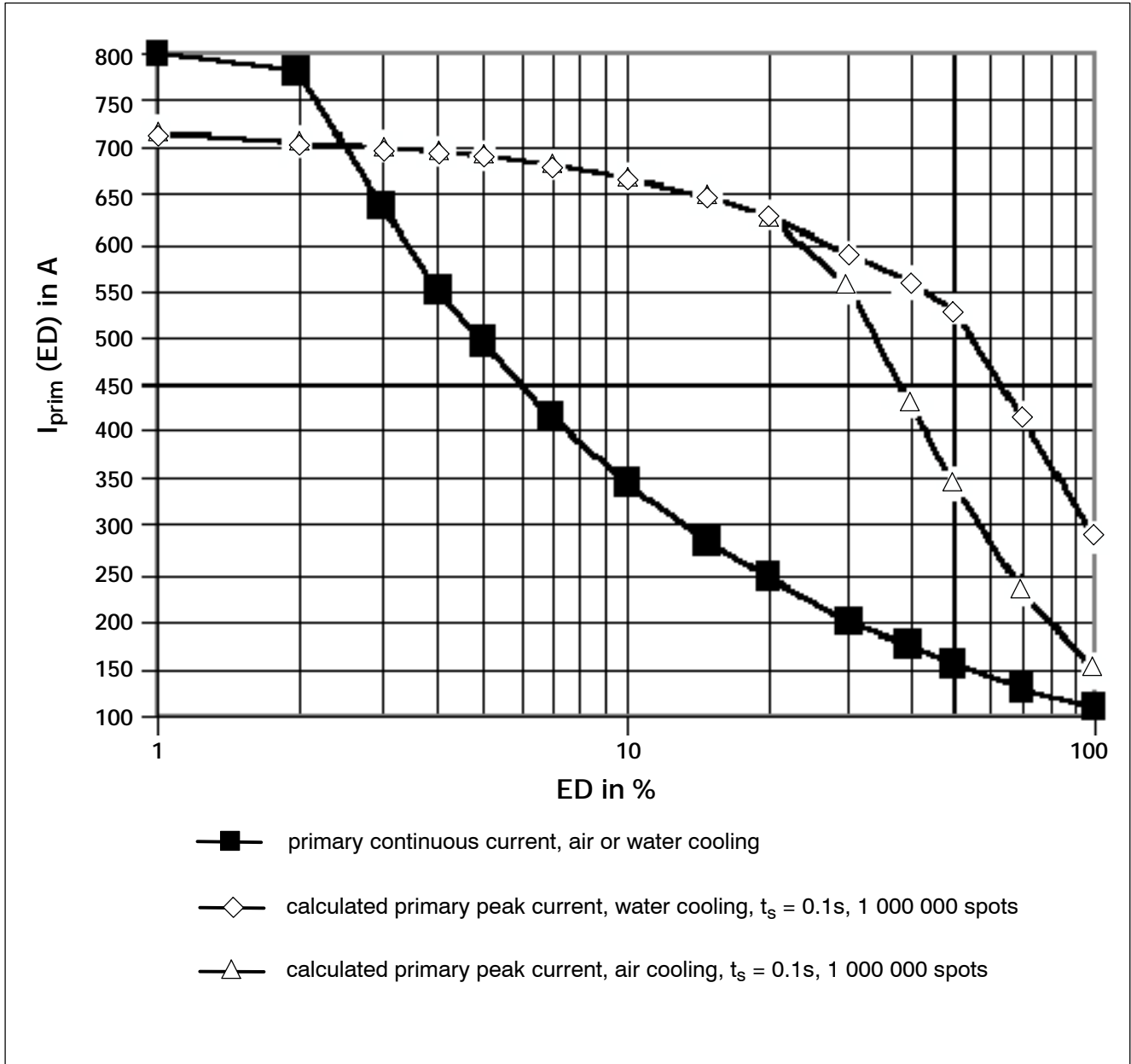

Load diagram, PSI 6300.XXX L2/W2

11.11 Accessories, PSI 6300.XXX L1/L2/W1/W2

11.11.1 Dimensioned drawing, accessories kit

An accessories kit is available for mounting the inverter with its back on the mounting plate.

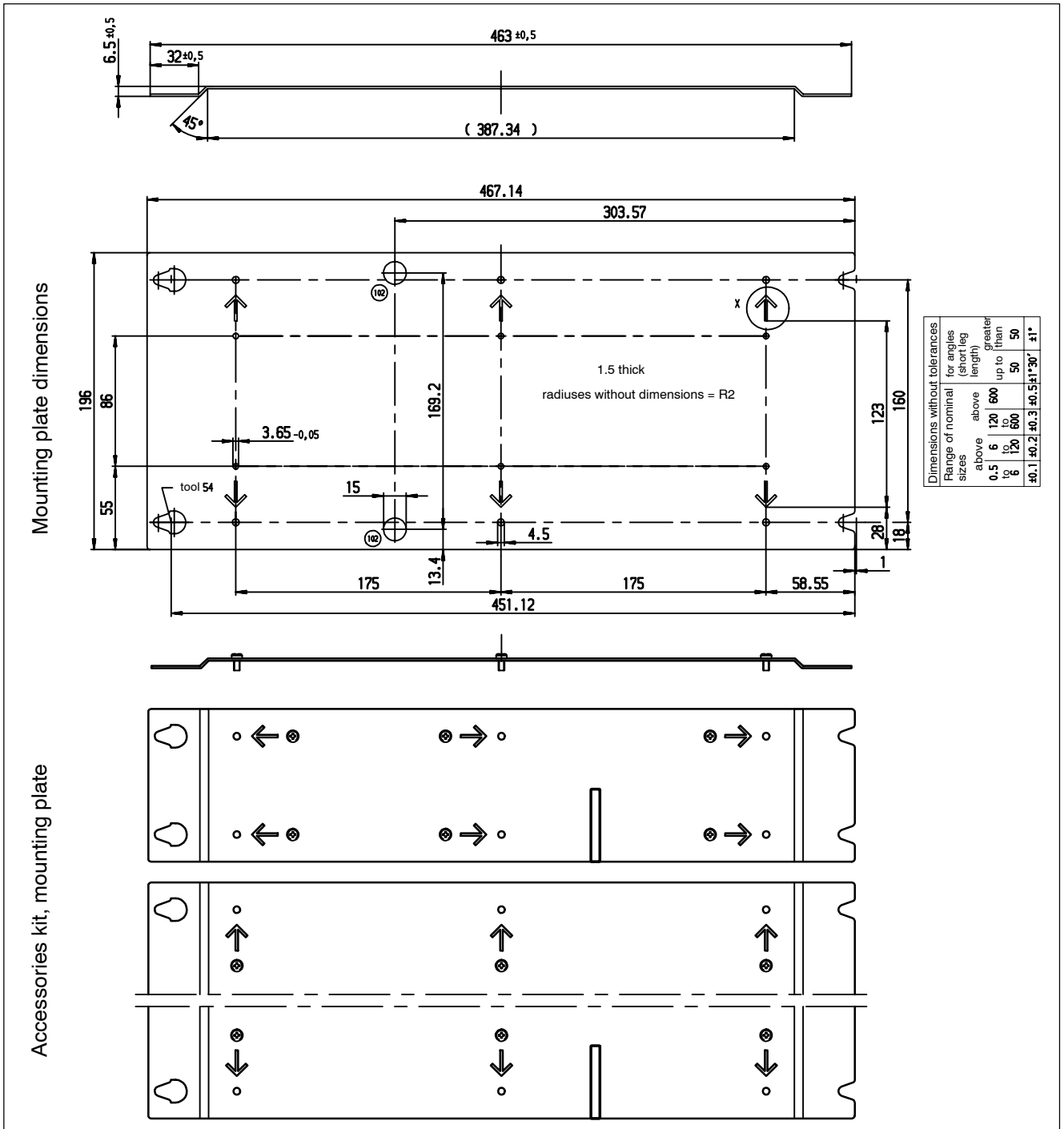

Dimensioned drawing, accessories kit

- D For PSG 3000 welding transformers, see Technical Information, PSG 3000 MF Welding Transformers, part no. 1070 080 087.
- D For I/O module, see Technical Information, PSI 6000, Control and I/O Level Description.
- D For insertable profiles for electric connection, see the section on ordering.

## 11.12 Ordering, PSI 6300.XXX L1/L2/W1/W2

Designation	Part no.
PSI 6300.100 L1 medium-frequency inverter	1070 081 688
PSI 6300.330 L1 medium-frequency inverter	1070 079 325
PSI 6300.321 L1 medium-frequency inverter	1070 081 689
PSI 6300.330 L2 medium-frequency inverter	1070 079 331
PSI 6300.100 W1 medium-frequency inverter	1070 084 595
PSI 6300.100 W2 medium-frequency inverter	on request

## Not included in shipment:

Designation	Part no.
Insertable profile for pin connectors on small wire sizes, line connection and welding transformer connection	1070 918 779
Accessories kit for PSI 6300.XXX L1/L2/W1/W2 mounting	1070 078 273
SSR 81.00 current sensor without fixing device, in the form of a toroid coil; 55 mm internal diameter; with 5-pole sleeve terminal	1070 048 099
SSR 81.01-08 current sensor with fixing device; e.g. for various electrode makes	on request
Mating connector for SSR 81.0X current sensor	1070 913 489
Sensor cable LiYCY 2x2x0,75 mm <sup>2</sup> shielded	1070 913 494

Notes:

## 12 PSI 6500.XXX W1

### 12.1 Explanation of drawings

The following drawings show the

- D front plate with modules of the MF inverter
  - D integrated weld timer
  - D slot for the parallel, serial or fieldbus I/O interface
  - D slot prepared for retrofitting a quality module
  - D slot for fieldbus interface for programming (optional)
- D technical data
- D dimensions and mounting options
- D mains connection
  - D connection of the PSG 3000 welding transformer
- D load diagram
- D accessories and part numbers

**Note: No water connections shown on drawings.**

12.2 PSI 6500.XXX W1 front panel

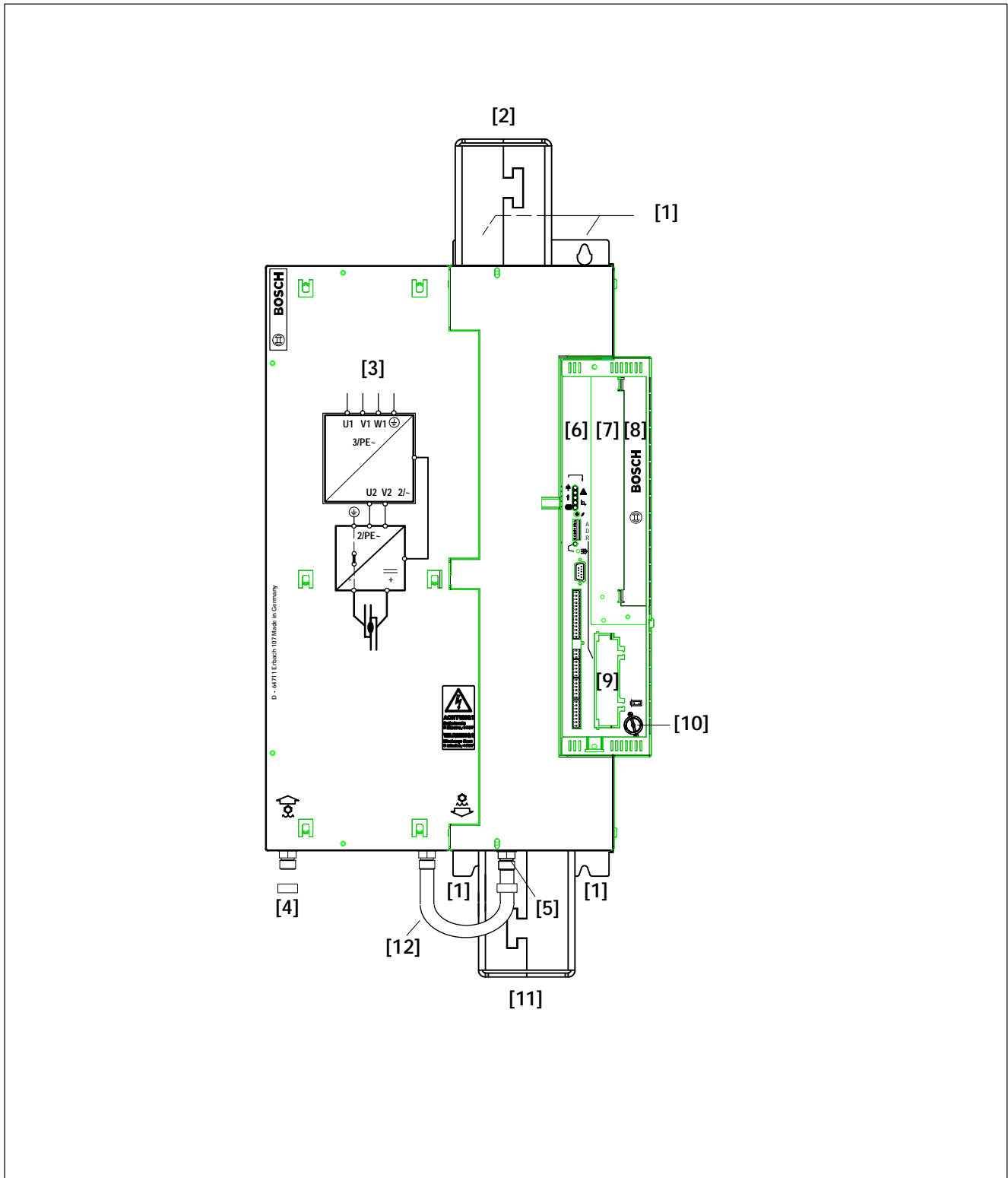

PSI 6500.XXX W1 front panel

- [1] M6 mounting options
  - D rear panel
- [2] mains supply connection with shrouding cover
- [3] MF inverter symbol
- [4] cooling water connection, supply  
nipple (brass) with standard taper bore IAW DIN EN 560,  
external thread M16x1.5
- [5] cooling water connection, discharge  
nipple (brass) with standard taper bore IAW DIN EN 560,  
external thread M16x1.5
- [6] integrated weld timer
- [7] slot for type-specific I/O interface:
  - D parallel I/O interface
  - D serial I/O interface
  - D fieldbus I/O interface
- [8] slot for retrofitting a quality module
- [9] slot for fieldbus interface for programming
- [10] battery compartment
- [11] PSG 3000 welding transformer connection (with shrouding cover)
- [12] hose connection between the two water coolers

## 12.3 Technical data, PSI 6500.XXX W1

Type	3-phase MF inverter, module designed for recessed mounting
Weld timer	integrated
I/O interface	Slot for parallel, serial or fieldbus interface
Quality module	Slot prepared for retrofitting
Degree of protection	IP 20; designed for modular enclosure or for installation in switchgear cabinets with IP 54
Inverter ambient temperature	max. 45° C; If thermal outputs exceed 50% of the rated output, a cabinet cooling system starts running, which adjusts the ambient temperature to 35° C.
Cooling	water 10 l/min.; max. 30° C
Temperature monitoring	integrated
Storage temperature	-25° C to +70° C
Corrosion	The ambient air must be free of acids, caustic solutions, corrosive agents, salts and metal vapors of any major concentration
Humidity	Humidity class F as per DIN 40040; 20° C at 90% relative humidity; 40° C at 50% relative humidity (as per VDE 0113); Moisture condensation on the MF inverters must be prevented.
Air pressure	Any within a range of up to 2000 m above sea level
Line voltage connection grounded TN or TT system	400 V -20% to 480 V +10%; 50/60 Hz
Nominal system current; max. continuous thermal current	660 A, with cubicle cooling unit
Max. output current	2400 A
Max. secondary current; depending on the transformer used	120 kA (PSG 3100)
Voltage supply; Weld timer CPU; I/O interface	24 V DC; min. 19 V DC up to max. 30 V DC as per EN 61131-2, (external power supply), or, alternatively, power supply from the weld current system (internal power supply)
Clock frequency	1 kHz
Overvoltage protection	MOV; Metal Oxide Varistor
Electrical connection, mains supply and transformer	with cable lugs; M10 bolts for each connection
Wire range	2 to 4 cables, 120 mm <sup>2</sup> each
Basic switchgear cabinet loss	100 W
Max. ventilating and cooling loss dissipated via external water-cooler	4400 W
Switchgear cabinet loss at max. power	850 W
Weight	approx. 70 kg, mech. load may be distributed
Mounting position	vertical or with its back on mounting plate

12.4 Dimensioned drawing, PSI 6500.XXX W1

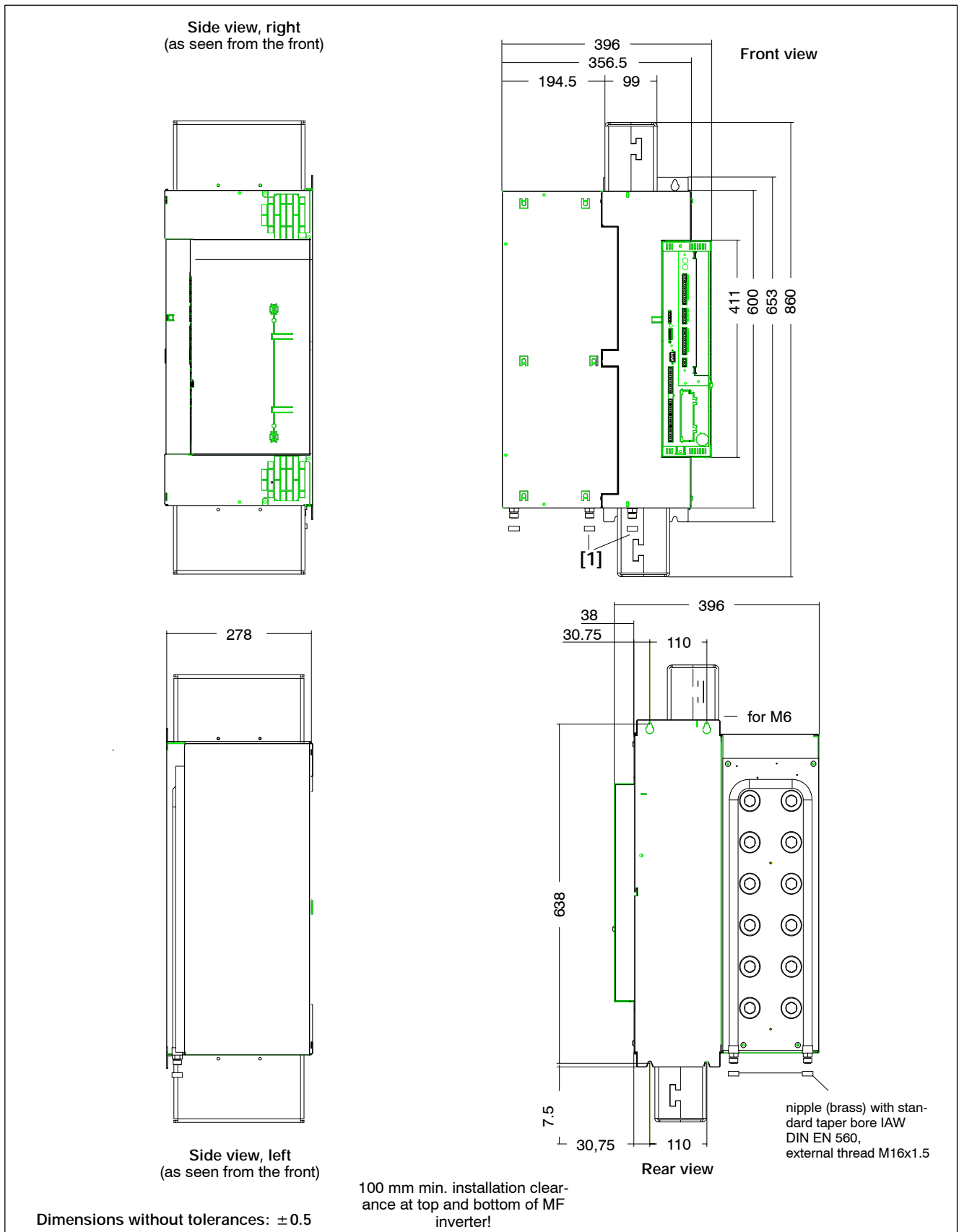

Dimensioned drawing, PSI 6500.XXX W1

## 12.5 Electrical connection, PSI 6500.XXX W1

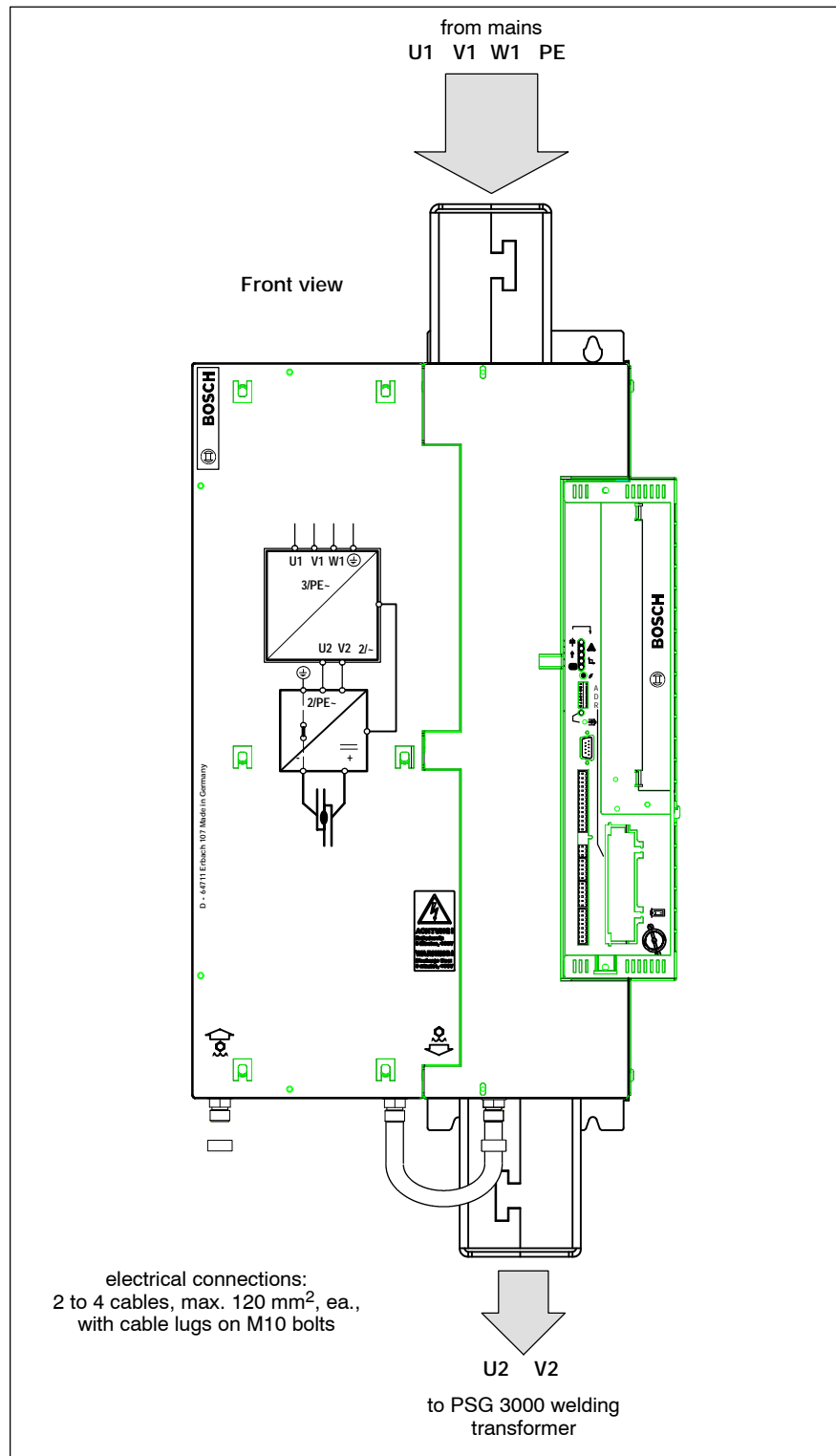

Electrical connection, PSI 6500.XXX W1

Note: For the connections of the various control functions, please see the respective manuals "PSI 6000, Control and I/O Level Description".

12.6 Cooling water connection, PSI 6500.XXX W1

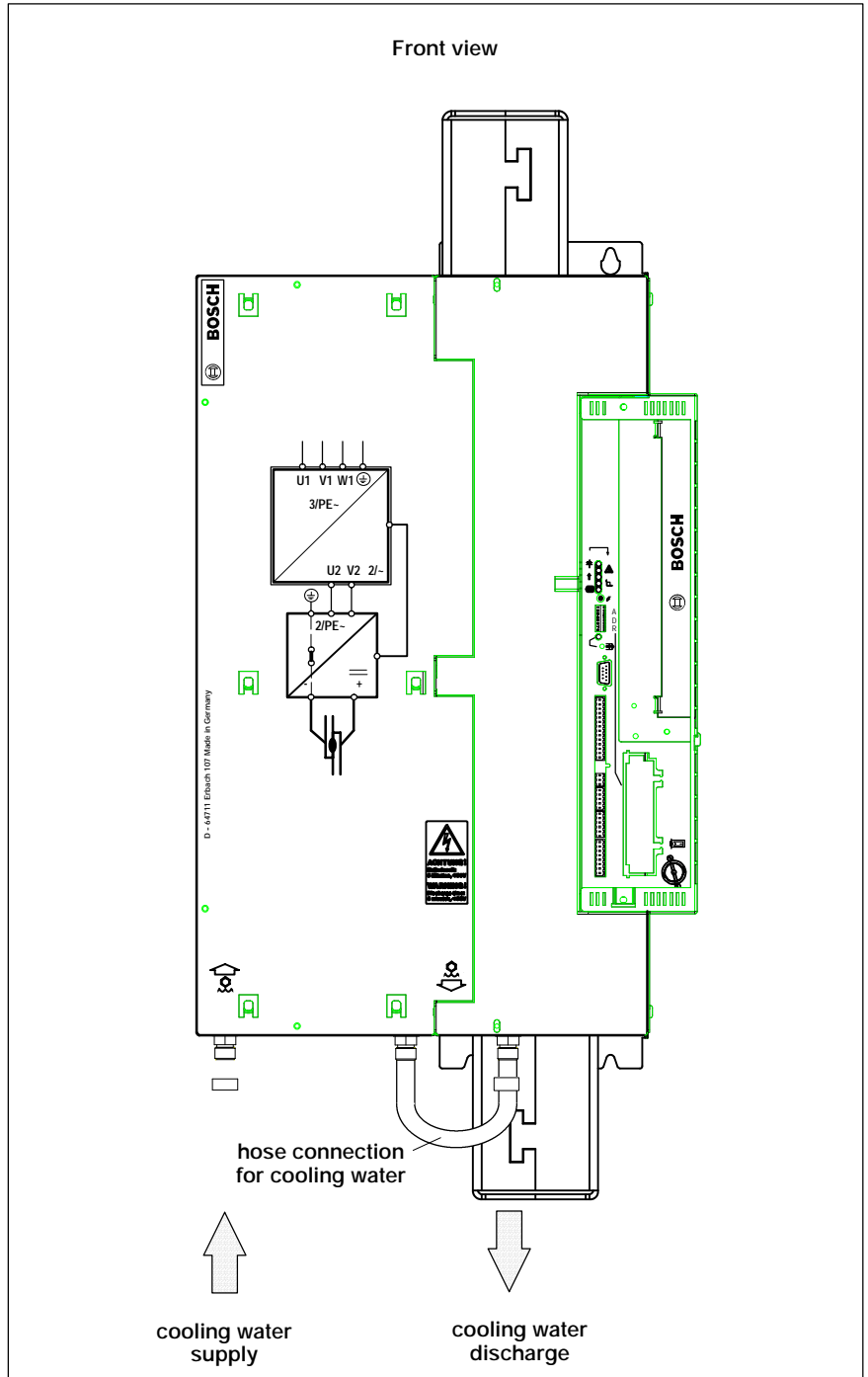

Cooling water connection, PSI 6500.XXX W1

The heat sink of the water-cooled MF inverter is connected internally to the protective earth conductor.

Maximum water inlet temperature : 30° C  
Water connection : M 16 x 1.5  
external thread (DIN EN 560,  
nut: DIN 13-6)

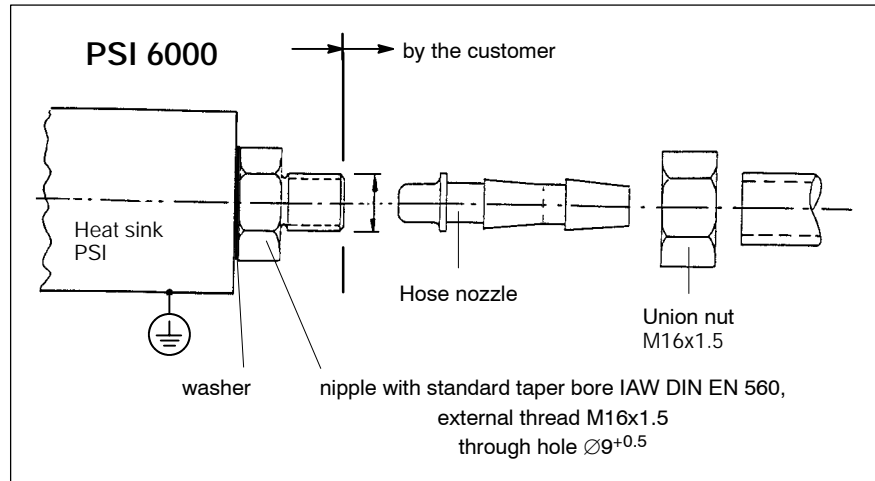

*Cooling water connection*

12.7 Load diagram, PSI 6500.XXX W1

Note: For a general description of load diagrams, see Section 3.1

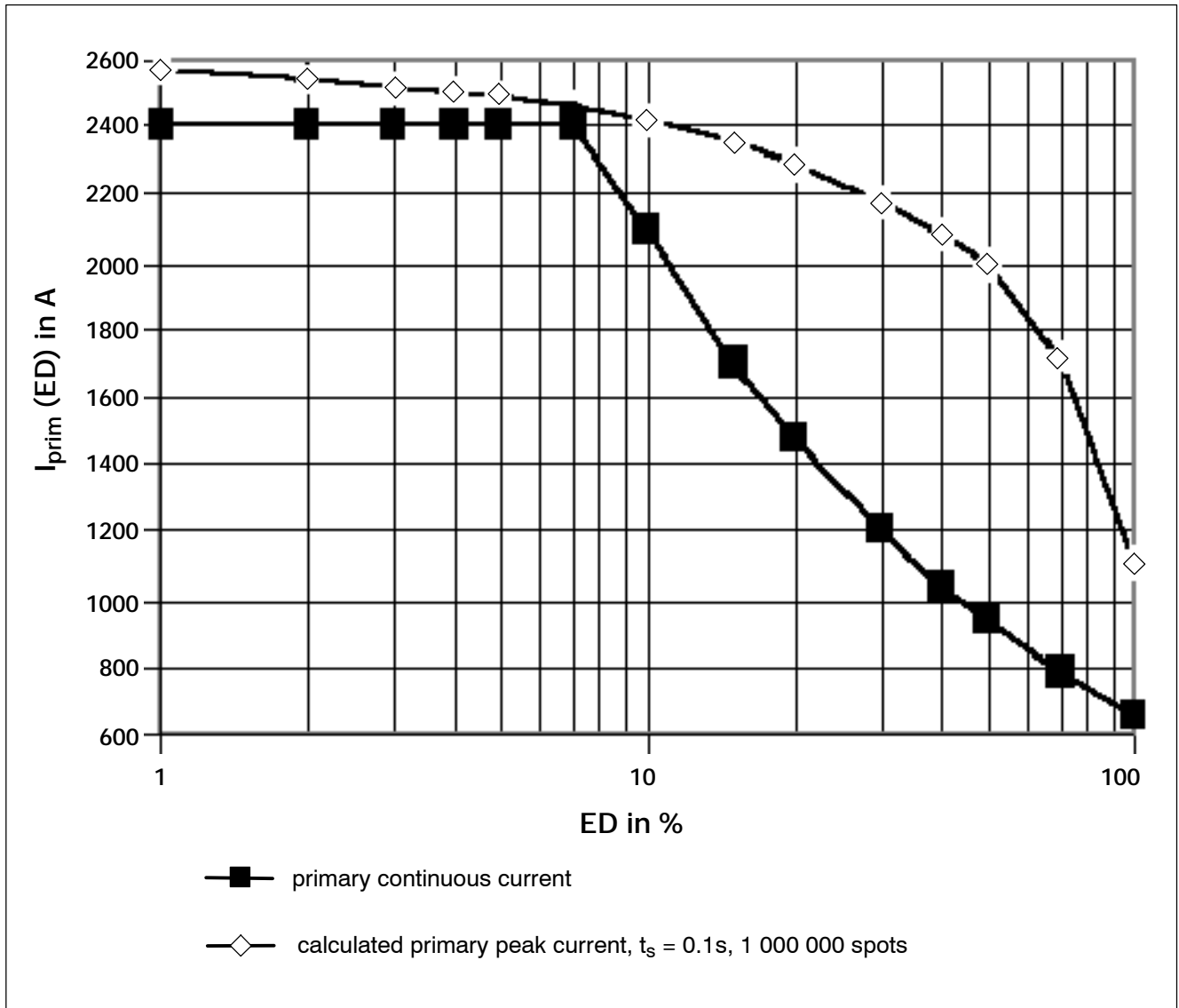

Load diagram, PSI 6500.XXX W1

## 12.8 Accessories, PSI 6500.XXX W1

- D For PSG 3000 welding transformers, see Technical Information, PSG 3000 MF Welding Transformers, part no. 1070 080 087.
- D For I/O module, see Technical Information, PSI 6000, Control and I/O Level Description.

## 12.9 Ordering, PSI 6500.XXX W1

Designation	Part no.
PSI 6500.XXX W1 medium-frequency inverter	1070 079 302

Not included in shipment:

Designation	Part no.
SSR 81.00 current sensor without fixing device, in the form of a toroid coil; 55 mm internal diameter; with 5-pole sleeve terminal	1070 048 099
SSR 81.01-08 current sensor with fixing device; e.g. for various electrode makes	on request
Mating connector for SSR 81.0X current sensor	1070 913 489
Sensor cable LiYCY 2x2x0,75 mm <sup>2</sup> shielded	1070 913 494

Notes:

# 13 CE declaration of conformity

EG Konformitätserklärung  
 EC declaration of conformity  
 Déclaration "CE"

Hiermit erklären wir, daß unser Produkt, Typ: PSI 6000  
 We hereby declare that our product, type:  
 Nous déclarons par la présente que notre produit, type: Typen gemäß beiliegender Liste

folgenden einschlägigen Bestimmungen entspricht:  **Maschinenrichtlinie** (89/392/EWG, 91/368/EWG, 93/68/EWG und 93/44/EWG)  
 complies with the following relevant provisions: **Machinery Directive** (89/392/EEC, 91/368/EEC, 93/68/EEC and 93/44/EEC)  
 correspond aux dispositions pertinentes suivantes: **Directive sur les machines** (89/392/CEE, 91/368/CEE, 93/68/CEE et 93/44/CEE)

**Niederspannungsrichtlinie** (73/23/EWG, 93/68/EWG und 93/44/EWG)  
**Low voltage Directive** (73/23/EEC, 93/68/EEC and 93/44/EEC)  
**Directive sur les basses tensions** (73/23/CEE, 93/68/CEE et 93/44/CEE)

**EMV-Richtlinie** (89/336/EWG, 93/68/EWG und 93/44/EWG)  
**EMC Directive** (89/336/EEC, 93/68/EEC and 93/44/EEC)  
**Directive EMV** (89/336/CEE, 93/68/CEE et 93/44/CEE)

Angewendete harmonisierte Normen, insbesondere:  
 Applied harmonized standards, in particular:  
 Normes harmonisées utilisées, notamment:  
EN 50081-2  
EN 50082-2  
EN 50178  
EN 60204-1

Angewendete nationale Normen und technische Spezifikationen, insbesondere:  
 Applied national technical standards and specifications, in particular:  
 Normes et specifications techniques nationales qui ont été utilisées, notamment:  
 \_\_\_\_\_  
 \_\_\_\_\_

Formular 1070074976 - 102W611

29.11.99 VB TEL  
 Datum / Unterschrift / Technische Betriebsleitung

25.11.1999 AT/EWS  
 Datum / Unterschrift / Entwicklungsleitung



Robert Bosch GmbH  
 Geschäftsbereich Automationstechnik  
 Betrieb Erbach  
 Postfach 1162  
 D-64701 Erbach/ Odw.

Sach-Nr. 1070 80297 -101\_474

Notes:

# A Annex

## A.1 Index

### A

Accessories kit, 8-10, 9-15, 11-15  
 Accessories PSI 6025.XXX L1, 8-8  
 Accessories PSI 6100.XXX L1/L2/W1/W2, 9-13  
 Accessories PSI 6200.XXX W1/W2, 10-11  
 Accessories PSI 6300.XXX L1/L2/W1/W2, 11-13  
 Accessories PSI 6500.XXX W1, 12-10  
 Air pressure, 8-4, 9-4, 10-4, 11-4, 12-4  
 Ambient temperature, 3-1, 8-4, 9-4, 10-4, 11-4, 12-4  
 Assembly, 1-6

### B

Basic switchgear cabinet loss, 8-4, 9-4, 10-4, 11-4, 12-4  
 Battery, 5-1  
 Battery compartment, 8-3, 9-3, 10-3, 11-3, 12-3  
 Block diagram of a medium-frequency inverter, 2-3

### C

Cables, 1-11  
 CE conformity, 1-18  
 CE declaration of conformity, 13-1  
 CE marking, 1-13  
 Clock frequency, 8-4, 9-4, 10-4, 11-4, 12-4  
 Commissioning, 4-1  
 Components, 2-2  
 Connection  
   U1, 1-11  
   U2, 1-11  
   V1, 1-11  
   V2, 1-11  
   W1, 1-11  
 Welding transformer, 1-11

Cooling, 9-4, 10-4, 11-4, 12-4

Cooling water, 1-8  
 Chlorides, 1-8  
 Degree of hardness, 1-8  
 Insoluble substances, 1-8  
 Nitrates, 1-8  
 pH value, 1-8  
 Sulfates, 1-8

Cooling water connection PSI 6100.XXX W1/W2, 9-9

Cooling water connection PSI 6200.XXX W1/W2, 10-7

Cooling water connection PSI 6300.XXX W1/W2, 11-9

Cooling water connection PSI 6500.XXX W1, 12-7

Corrosion, 8-4, 9-4, 10-4, 11-4, 12-4

Current sensor, 8-10, 9-15, 10-12, 11-15, 12-11

### D

Degree of protection, 8-4, 9-4, 10-4, 11-4, 12-4  
 Dimensioned drawing PSI 6025.XXX L1, 8-5  
 Dimensioned drawing PSI 6100.XXX L1/L2, 9-6  
 Dimensioned drawing PSI 6100.XXX W1/W2, 9-7  
 Dimensioned drawing PSI 6200.XXX W1/W2, 10-5  
 Dimensioned drawing PSI 6300.XXX L1/L2, 11-6  
 Dimensioned drawing PSI 6300.XXX W1/W2, 11-7  
 Dimensioned drawing PSI 6500.XXX W1, 12-5  
 Dimensioned drawing, accessories kit, 8-8, 9-13, 11-13  
 Duty cycle, 3-1

### E

ED duty cycle, 3-1  
 Electrical connection, 1-9, 8-4, 9-4, 10-4, 11-4, 12-4  
 Electrical connection PSI 6025.XXX L1, 8-6

Electrical connection PSI 6100.XXX L1/L2/W1/W2, 9-8

Electrical connection PSI 6200.XXX W1/W2, 10-6

Electrical connection PSI 6300.XXX L1/L2/W1/W2, 11-8

Electrical connection PSI 6500.XXX W1, 12-6

EMC, 1-13

EMERGENCY-STOP facilities, 1-16, 5-1

## F

Features, 2-1, 7-1

Field bus module, 2-2

Fieldbus interface for programming, 8-1, 9-1, 10-1, 11-1, 12-1

Function, 2-4

## H

Heat sink, 8-4, 9-10, 10-8, 11-10, 12-8

Humidity, 8-4, 9-4, 10-4, 11-4, 12-4

## I

I/O interface, 2-2, 8-1, 8-4, 9-1, 9-4, 10-1, 10-4, 11-1, 11-4, 12-1, 12-4

I/O module, 8-9, 9-14, 10-11, 11-14, 12-10

Insertable profile, 8-10, 9-15, 11-15

Installation, 1-6

Integrated weld timer, 8-1, 9-1, 10-1, 11-1, 12-1

Intended use, 1-3

## L

Line voltage connection, 8-4, 9-4, 10-4, 11-4, 12-4

Load capability, 3-1

Load diagram, 3-1

Load diagram PSI 6025.XXX L1, 8-7

Load diagram PSI 6100.XXX L1/W1, 9-11

Load diagram PSI 6100.XXX L2/W2, 9-12

Load diagram PSI 6200.XXX W1, 10-9

Load diagram PSI 6200.XXX W2, 10-10

Load diagram PSI 6300.XXX L1/W1, 11-11

Load diagram PSI 6300.XXX L2/W2, 11-12

Load diagram PSI 6500.XXX W1, 12-9

## M

Mains supply, 8-4, 9-4, 10-4, 11-4, 12-4

Maintenance, 1-16, 5-1, 5-2

Malfunction, 6-1

Malfunctions, 6-1

Max. output current, 8-4, 9-4, 10-4, 11-4, 12-4

Max. secondary current, 8-4, 9-4, 10-4, 11-4, 12-4

Maximum welding current, 3-1, 1-14

Medium-frequency welding

Advantages, 2-6

Benefits, 2-6

Modifications, 1-2

Modifications by the user, 1-15

Modules, 2-2

Monitoring, 2-5

Monitoring functions, 2-5

Mounting, 1-6

Mounting position, 8-4, 9-5, 10-4, 11-5, 12-4

## N

Nominal system current, 8-4, 9-4, 10-4, 11-4, 12-4

Notes on rating, 3-1

## O

Operation, 1-14

Ordering PSI 6100.XXX L1/L2/W1/W2, 9-15

Ordering PSI 6200.XXX W1/W2, 10-12

Ordering PSI 6300.XXX L1/L2/W1/W2, 11-15

Ordering PSI 6500.XXX W1, 12-11

Ordering, PSI 6025.XXX L1, 8-10

Output currents, 3-1

Overall weld cycle duration, 3-1

Overload, 2-5

Overvoltage protection, 8-4, 9-4, 10-4, 11-4, 12-4

## P

Pacemaker, 1-4

PE connection, 1-11

Primary voltage, 2-4

PSI 6025.XXX L1, 8-1  
 PSI 6025.XXX L1 front panel, 8-2  
 PSI 6100.XXX L1/L2/W1/W2, 9-1  
 PSI 6100.XXX L1/L2/W1/W2 front panel, 9-2  
 PSI 6100.XXX L1/L2/W1/W2 overview, 9-1  
 PSI 6200.XXX W1/W2, 10-1  
 PSI 6200.XXX W1/W2 front panel, 10-2  
 PSI 6200.XXX W1/W2 overview, 10-1  
 PSI 6300.XXX L1/L2/W1/W2, 11-1  
 PSI 6300.XXX L1/L2/W1/W2 front panel, 11-2  
 PSI 6300.XXX L1/L2/W1/W2 overview, 11-1  
 PSI 6500.XXX W1, 12-1  
 PSI 6500.XXX W1 front panel, 12-2

## Q

Qualified personnel, 1-5  
 Quality module, 2-2, 8-1, 8-4, 9-1, 9-4, 10-1, 10-4, 11-1, 11-4, 12-1, 12-4

## R

"Ready" LED, 6-1  
 "Ready" message, 6-1  
 Repair, 1-16, 5-2  
 Replacement parts, 5-2  
 Residual-current circuit-breaker, 1-10  
 Retrofits, 1-15

## S

Safety instructions, 1-1, 1-2  
 Secondary current, 2-4  
 Sensor cable, 8-10, 9-15, 10-12, 11-15, 12-11  
 Setup, 2-1  
 Spare parts, 1-16, 5-2  
 Storage temperature, 8-4, 9-4, 10-4, 11-4, 12-4  
 Switchgear cabinet loss, 8-4, 9-5, 10-4, 11-5, 12-4  
 Symbols, 1-2  
 System perturbation, 1-12

## T

Technical data PSI 6025.XXX L1, 8-4

Technical data PSI 6100.XXX L1/L2/W1/W2, 9-4  
 Technical data PSI 6200.XXX W1/W2, 10-4  
 Technical data PSI 6300.XXX L1/L2/W1/W2, 11-4  
 Technical data PSI 6500.XXX W1, 12-4  
 Temperature monitoring, 8-4, 9-4, 10-4, 11-4, 12-4  
 Test procedures, 1-16, 5-1  
 Thermal detector, 6-1  
 Thyristor load, 3-1  
 Thyristor unit temperature, 6-1  
 Training courses, 1-5  
 Type, 8-4, 9-4, 10-4, 11-4, 12-4  
 Type overview, 7-1

## V

Ventilating and cooling loss, 8-4, 9-5, 10-4, 11-5, 12-4  
 Voltage supply, 8-4, 9-4, 10-4, 11-4, 12-4

## W

Weight, 8-4, 9-5, 10-4, 11-5, 12-4  
 Weld time, 3-1  
 Weld timer, 2-2, 8-4, 9-4, 10-4, 11-4, 12-4  
 Welding current, maximum, 1-14  
 Welding splashes, 1-17  
 Welding transformer, 8-9, 9-14, 10-11, 11-14, 12-10  
 Wire range, 8-4, 9-4, 10-4, 11-4, 12-4  
 Working safely, 1-17

Notes:

